

EVOPUS⁺ LITE

ELECTRONIC CIRCULATORS



EVOPLUS LITE/ EVOPLUS LITE SAN

WET ROTOR ELECTRONIC CIRCULATORS



TECHNICAL DATA

Operating range: from 2 to 12,5 m³/h with up to 12 meters head;
Liquid temperature range: -20 °C to +110 °C
Fluid pumped: clean, free of solids and mineral oils, non-viscous, chemically neutral, properties akin to water. (max. glycol 50%).
Maximum working pressure: 16 bar (1600 kPa)
Standard flanged connections: DN 32, DN 40 PN 6 / PN 10 / PN 16 (4 slots)
Maximum ambient temperature: + 40°C.
Required NPSH: the values are given in the relevant tables.
Accessories: ½"F, ¾"F, 1"F, 1"¼F, 1"¼M union fittings
DN 32 PN 10 and DN 40 PN 10 threaded mating flanges.
Circulator protection rating: IPX4
Insulation class: F
Standard voltage: single phase 220 - 240 V, 50/60Hz
Sound pressure level: ≤ 33 dB(A)

APPLICATIONS

The Evoplus Lite electronic circulator pumps can be used in HVAC systems for residential and commercial buildings such as:

- Large residential buildings
- Condominiums and small apartment buildings
- Houses
- Properties
- Clinics and hospitals
- Schools
- Office buildings

Single version available with 1½" and 2" threaded connections, and with DN 32 and DN 40, PN 6 / PN 10 / PN 16 flanged connections.
Special version available with bronze pump casing for domestic hot water recirculation.

HEATING APPLICATIONS

The heating required in different applications varies significantly from day to night as a result of the outside temperature and whether or not the interiors are constantly occupied. Other factors to take into consideration include the different needs of the various rooms and whether different branches within complex systems may be opened or closed. Electronically controlled wet rotor pumps offer consistent performance, in practically all correctly sized systems, ensuring a sufficient amount of energy at all times and, at the same time, quieter operation and greater comfort with a considerable reduction in running costs.

AIR-CONDITIONING APPLICATIONS

Unlike conventional electronic pumps, Evoplus Lite electronic circulator pumps can also be used in air-conditioning systems where the temperature of the pumped fluid is lower than the ambient temperature. Even in these conditions, the condensation that forms on the outside of the circulator does not affect the operation of either the pump's electronics or its mechanical components. The special design has been engineered and sized accordingly to allow the condensate to drain away without damaging the components making up the pump.

DHW RECIRCULATION APPLICATIONS

The SAN version, featuring a bronze pump casing, has been specifically developed for recirculating domestic hot water: using the constant-temperature operating mode, the temperature of the water in the recirculation piping is controlled, without the need to use thermostatic valves, thus optimizing comfort.

DESIGN FEATURES

Close-coupled circulator pump comprising cast iron hydraulics and wet rotor synchronous electric motor. Aluminium motor housing. Volute pump casing built for impressive hydraulic efficiency thanks to its meticulous design and honed internal surfaces. Inline inlet and outlet. The product has optional insulation shells that can be purchased separately should you need to avoid heat loss and/or condensation forming on the pump casing. Installers can also produce their own insulation. Take care not to block the 4 condensate drain holes located on the pump casing/motor coupling so as not to compromise the circulator's operation. Evoplus Lite circulators for small community systems are connected to the power supply line by means of a practical connector, designed with superseal technology, which comes as standard and makes the task quick and easy. Technopolymer impeller, aluminium motor shaft mounted on graphite bearings lubricated by the actual fluid being pumped. Synchronous motor with permanent magnet rotor. The standard pump casing arrangement is PN 16, flanged version with 4 slots compatible with PN 6 / PN 10 / PN 16 mating flanges so that the pumps can be swapped in and out of existing systems.

EVOPLUS LITE / EVOPLUS LITE SAN

WET ROTOR ELECTRONIC CIRCULATORS

DESIGN FEATURES OF EVOPLUS FOR SMALL COMMUNITY SYSTEMS (ELECTRONIC DEVICE)

EVOPLUS circulators are controlled by an IGBT-based device employing latest generation NPT technology for greater efficiency and ruggedness. Its specific features are as follows:

- Sensorless motor control
- Sinusoidal PWM
- High carrier frequency to eliminate all noise in audio band
- Dedicated 32-bit processor
- Optimized „space vector“ algorithm

Courtesy of a functional, intuitive user interface, you can configure the circulator quickly and easily with a single button. Evoplus Lite is the perfect candidate for systems of all kinds: it can adjust the flow rate, adapting to suit the system's characteristics; all the installer needs to do is select the curve and type of control.

MATERIALI

No.	PARTS	MATERIALS
1	PUMP CASING	CAST IRON 250 UNI ISO 185 - CTF BRONZE (for SAN version)
2	IMPELLER	TECHNOPOLYMER
3	MOTOR SHAFT	ALUMINIUM
4	ROTOR	STAINLESS STEEL
5	STATOR	-
6	MOTOR HOUSING	DIE-CAST ALUMINIUM
7	O-RING	EPDM RUBBER
8	STATOR SLEEVE	STAINLESS STEEL
9	END FLANGE	STAINLESS STEEL
10	THRUST RING MOUNT	EPDM RUBBER
11	BEARINGS	GRAPHITE
12	SHIM WASHER	STAINLESS STEEL
13	BLEED CAP	BRASS
14	VARIABLE FREQUENCY DRIVE BOX	POLYCARBONATE

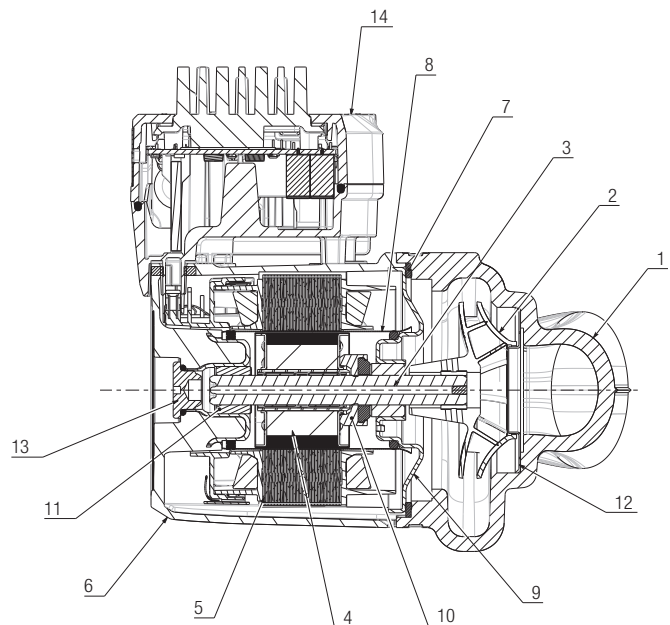

- Legend: (example)

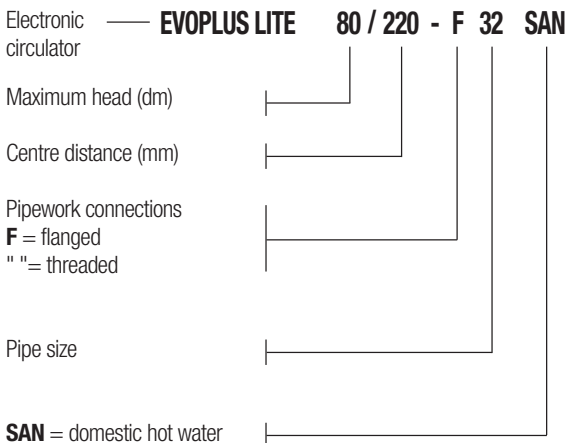

EVOPLUS LITE / EVOPLUS LITE SAN

WET ROTOR ELECTRONIC CIRCULATORS

OPERATING MODES

All users (regardless of their role) can view all the functions listed below by simply scrolling down the menu. Parameter setting and editing is protected and restricted to expert users only. The EVOPLUS range is factory set to proportional differential pressure control on the curve that ensures the best energy efficiency index (EEI).

1 - Proportional differential pressure control mode $\Delta P-v$

The $\Delta P-v$ control mode varies the head delivery value linearly from H_{setp} to $H_{setp}/2$ as the flow rate varies.

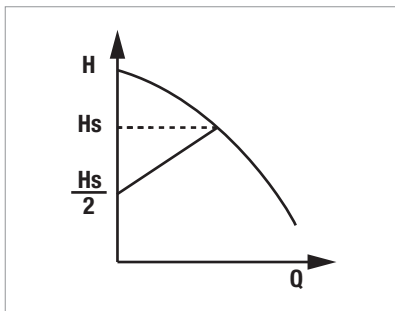

This control option is particularly well suited to the following systems:

a. Two-pipe heating systems with thermostatic valves and with:

- a head greater than 4 metres;
- very lengthy piping;
- valves with broad working range;
- differential pressure regulators;
- large pressure losses in those parts of the system experiencing the full amount of water flow;
- low differential temperature.

b. Underfloor heating systems and systems with thermostatic valves and large pressure losses in the boiler circuit.

c. Systems with primary circuit pumps with high pressure losses

Example of unit setup with $\Delta P-v$

The following duty point is required:

$$Q = 4 \text{ m}^3/\text{h}$$

$$H = 6 \text{ m}$$

PROCEDURE:

1. Mark the desired duty point on the graph and locate the proportional control curve of your Evoplus Lite model that is closest to the desired duty point.
2. In the case of our example with $Q = 4 \text{ m}^3/\text{h}$ and $H = 6 \text{ m}$, the proportional control curve closest to this duty point is **PP2**.

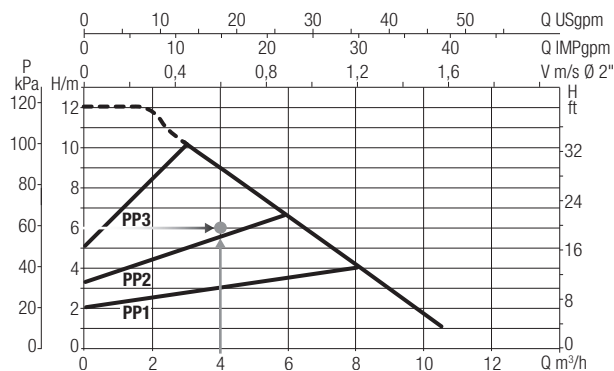

2 - Constant differential pressure control mode $\Delta P-c$

The $\Delta P-c$ control mode keeps the system's differential pressure constant at the settable H_{setp} value as the flow rate varies.

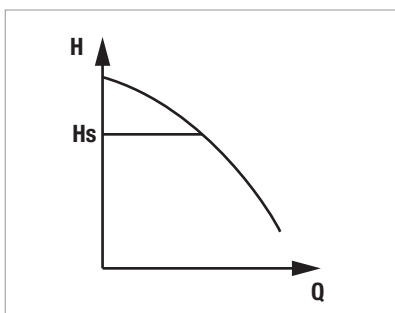

This control option is particularly well suited to the following systems:

a. Two-pipe heating systems with thermostatic valves and with:

- a head less than 2 metres;
- natural circulation;
- low pressure losses in those parts of the system experiencing the full amount of water flow;
- high differential temperature (central heating).

b. Underfloor heating systems with thermostatic valves

c. One-pipe heating systems with thermostatic valves and adjustment valves

d. Systems with primary circuit pumps with low pressure losses

3 - Constant curve control mode

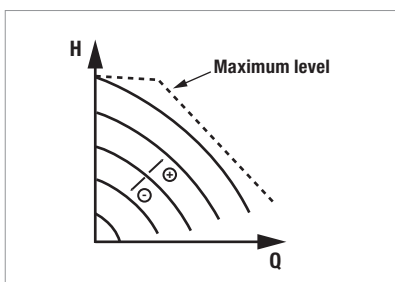

In this control mode, the circulator works on characteristic curves at constant speed. The performance curve is selected by setting rpm by means of a percentage factor. The value 100% indicates the maximum limit curve. Actual rpm may depend on the power and differential pressure limitations of your circulator model. Rpm can be set via the display or with a 0-10V external signal.

Control option recommended for constant-flow heating and air-conditioning systems.

EVOPLUS RANGE

WET ROTOR ELECTRONIC CIRCULATORS

PERFORMANCE RANGE

The performance curves are based on kinematic viscosity values = 1 mm²/s and density equal to 1000 kg/m³. Curve tolerance according to ISO 9906.

GRAPHIC SELECTION TABLE

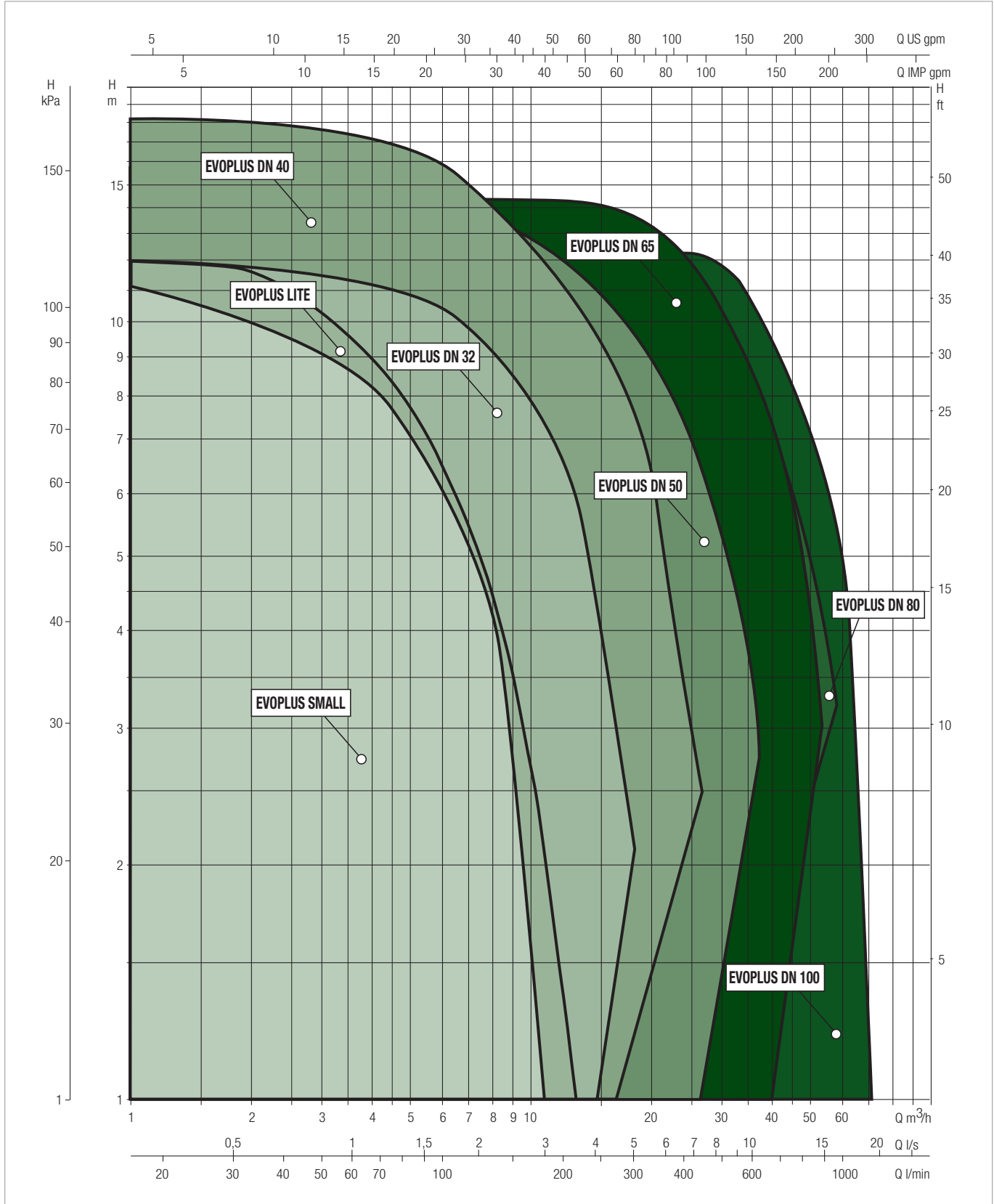

EVOPLUS LITE / EVOPLUS LITE SAN

WET ROTOR ELECTRONIC CIRCULATORS

SELECTION TABLE - EVOPLUS LITE

MODEL	Q=m ³ h	0	1,8	2,4	3	4,2	5,4	6,6	7,8	9	10,2	11,4
	Q=l/min	0	30	40	50	70	90	110	130	150	170	190
EVOPLUS LITE 60/180-25	H (m)	6,1	6,1	6,0	5,6	4,6	3,4	2,2	1,0			
EVOPLUS LITE 60/180-32		6,1	6,1	6,0	5,6	4,6	3,4	2,2	1,0			
EVOPLUS LITE 60/220-F32		6,0	6,0	6,0	5,5	4,5	3,5	2,6	1,6	0,7		
EVOPLUS LITE 60/250-F40		6,0	6,0	6,0	5,5	4,5	3,5	2,6	1,6	0,7		
EVOPLUS LITE 80/180-25		8,0	8,0	7,9	7,5	6,2	4,8	3,5	2,2	0,9		
EVOPLUS LITE 80/180-32		8,0	8,0	7,9	7,5	6,2	4,8	3,5	2,2	0,9		
EVOPLUS LITE 80/220-F32		8,0	8,0	7,8	6,9	5,8	4,7	3,6	2,5	1,5		
EVOPLUS LITE 80/250-F40		8,0	8,0	7,9	7,0	5,9	4,9	3,9	2,8	1,8	0,8	
EVOPLUS LITE 120/180-25		12,0	12,0	11,5	10,0	8,5	7,1	5,7	4,3	2,9	1,5	
EVOPLUS LITE 120/180-32		12,0	12,0	11,5	10,0	8,5	7,1	5,7	4,3	2,9	1,5	
EVOPLUS LITE 120/220-F32		12,0	12,0	10,6	9,7	8,5	7,3	6,1	4,9	3,7	2,5	1,3
EVOPLUS LITE 120/250-F40		12,0	12,0	10,6	9,7	8,5	7,3	6,1	4,9	3,7	2,5	1,3

SELECTION TABLE - EVOPLUS LITE SAN

MODEL	Q=m ³ h	0	1,8	2,4	3	4,2	5,4	6,6	7,8	9	10,2	11,4
	Q=l/min	0	30	40	50	70	90	110	130	150	170	190
EVOPLUS LITE SAN 60/180-25	H (m)	6,1	6,1	6,0	5,6	4,6	3,4	2,2	1,0			
EVOPLUS LITE SAN 60/220-F32		6,0	6,0	6,0	5,5	4,5	3,5	2,6	1,6	0,7		
EVOPLUS LITE SAN 60/250-F40		6,0	6,0	6,0	5,5	4,5	3,5	2,6	1,6	0,7		
EVOPLUS LITE SAN 80/180-25		8,0	8,0	7,9	7,5	6,2	4,8	3,5	2,2	0,9		
EVOPLUS LITE SAN 80/220-F32		8,0	8,0	7,8	6,9	5,8	4,7	3,6	2,5	1,5		
EVOPLUS LITE SAN 80/250-F40		8,0	8,0	7,9	7,0	5,9	4,9	3,9	2,8	1,8	0,8	
EVOPLUS LITE SAN 120/180-25		12,0	12,0	11,5	10,0	8,5	7,1	5,7	4,3	2,9	1,5	
EVOPLUS LITE SAN 120/220-F32		12,0	12,0	10,6	9,7	8,5	7,3	6,1	4,9	3,7	2,5	1,3
EVOPLUS LITE SAN 120/250-F40		12,0	12,0	10,6	9,7	8,5	7,3	6,1	4,9	3,7	2,5	1,3

EVOPLUS LITE 60/180-25 - WET ROTOR ELECTRONIC CIRCULATORS

Pumped liquid temperature range: from -20°C up to +110°C - Maximum operating pressure: 16 bar (1600 kPa)

EVOPLUS LITE 60/180-25

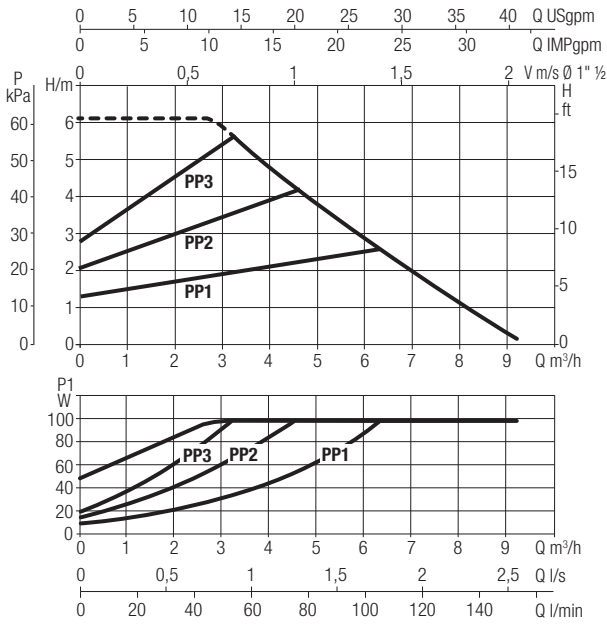

EVOPLUS LITE 60/180-25

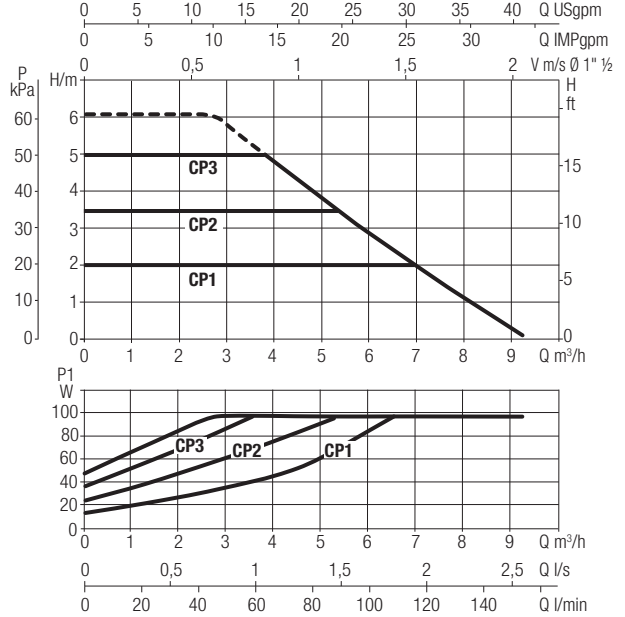

EVOPLUS LITE 60/180-25

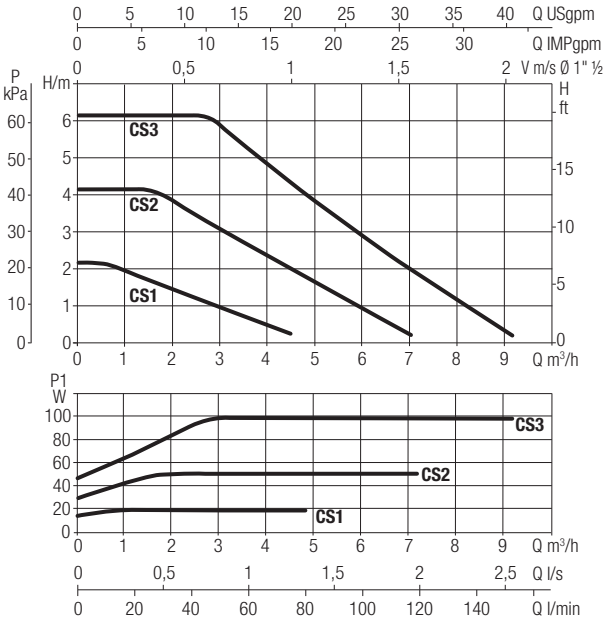

PPx = Proportional Differential Pressure - curve x
CPx = Constant Differential Pressure - curve x
CSx = Constant Speed - curve x

The curves are based on kinematic viscosity values = 1 mm²/s and density equal to 1000 kg/m³. Curve tolerance according to ISO 9906. Fixed speed curves available on the DNA.

MODEL	CENTRE DISTANCE mm	COUNTERFLANGES ON REQUEST	POWER INPUT 50/60 Hz	P1 MAX W	In A	EEI*	MINIMUM SUCTION PRESSURE			Q.TY x PALLET	WEIGHT Kg
							t°	90°	100°		
EVOPLUS LITE 60/180-25	180	-	220/240 V	98	0,78	EEI ≤ 0,20	m.c.w	20	25	92	3,4

* The parameter of reference for the more efficient circulators is EEI ≤ 0,20.

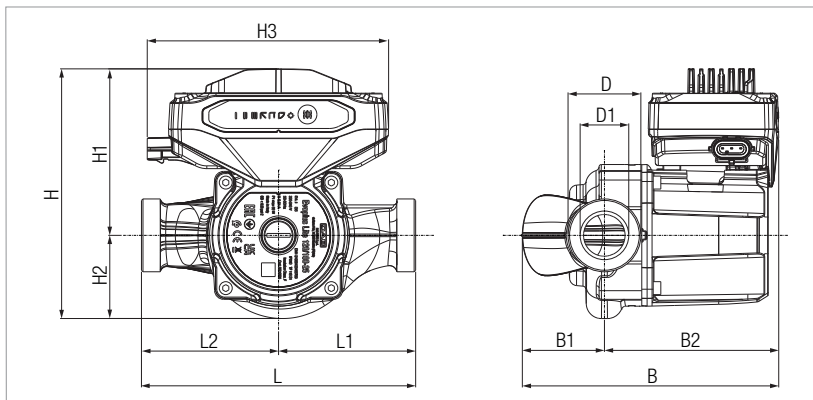

B	B1	B2	D	D1	H
168	54	114	1½"	32	164

H1	H2	H3	L	L1	L2
109	55	159	180	90	90

EVOPLUS LITE 60/180-32 - WET ROTOR ELECTRONIC CIRCULATORS

Pumped liquid temperature range: from -20°C up to +110°C - Maximum operating pressure: 16 bar (1600 kPa)

EVOPLUS LITE 60/180-32

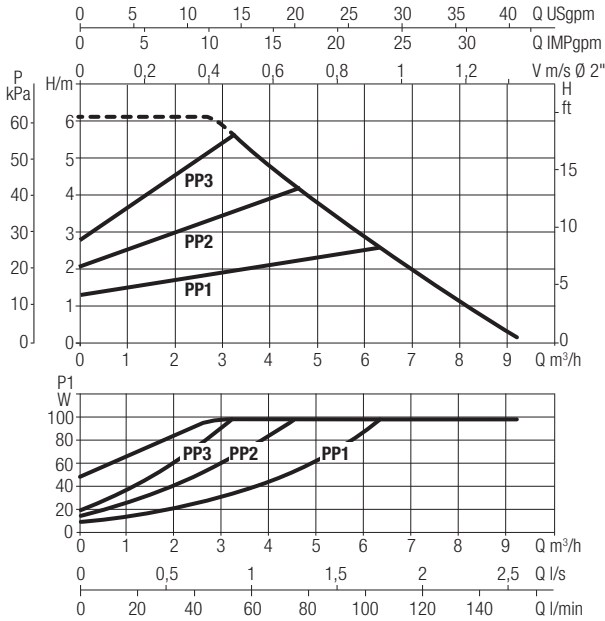

EVOPLUS LITE 60/180-32

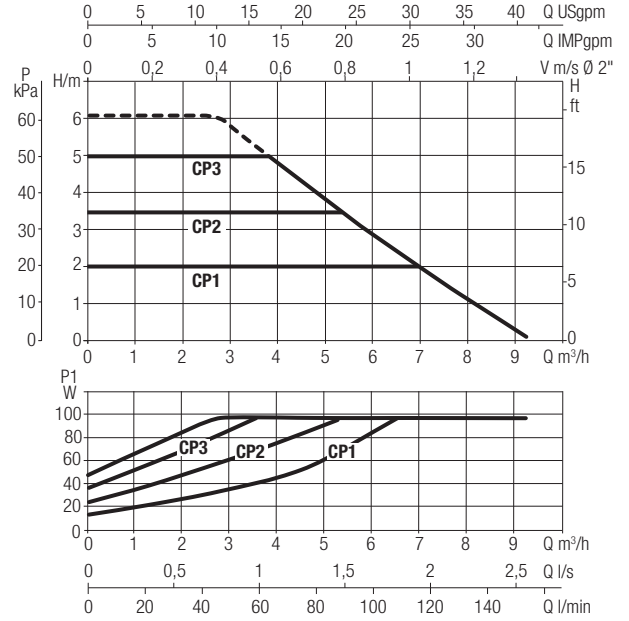

EVOPLUS LITE 60/180-32

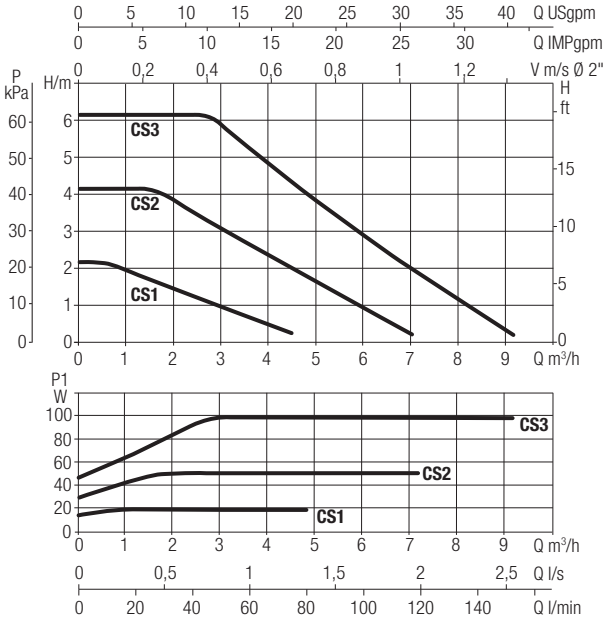

PPx = Proportional Differential Pressure - curve x
CPx = Constant Differential Pressure - curve x
CSx = Constant Speed - curve x

The curves are based on kinematic viscosity values = 1 mm²/s and density equal to 1000 kg/m³. Curve tolerance according to ISO 9906. Fixed speed curves available on the DNA.

MODEL	CENTRE DISTANCE mm	COUNTERFLANGES ON REQUEST	POWER INPUT 50/60 Hz	P1 MAX W	In A	EEI*	MINIMUM SUCTION PRESSURE			Q.TY x PALLET	WEIGHT Kg
							t°	90°	100°		
EVOPLUS LITE 60/180-32	180	-	220/240 V	98	0,78	EEI ≤ 0,20	m.c.w	20	25	92	3,5

* The parameter of reference for the more efficient circulators is EEI ≤ 0,20.

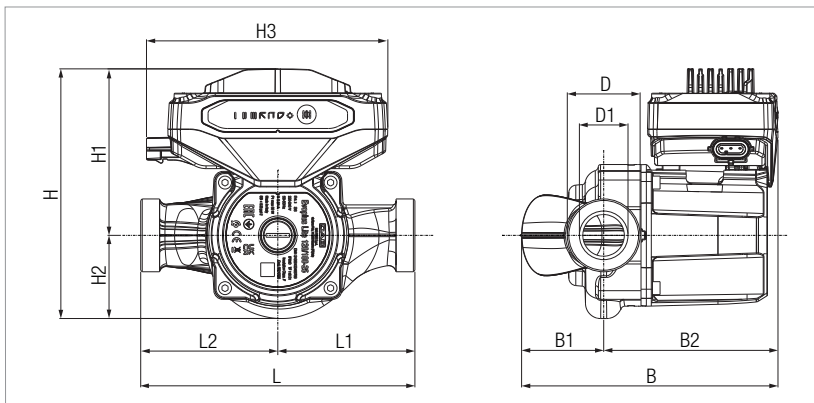

B	B1	B2	D	D1	H
168	54	114	2"	32	164

H1	H2	H3	L	L1	L2
109	55	159	180	90	90

EVOPLUS LITE 60/220-F32 - WET ROTOR ELECTRONIC CIRCULATORS

Pumped liquid temperature range: from -20°C up to +110°C - Maximum operating pressure: 16 bar (1600 kPa)

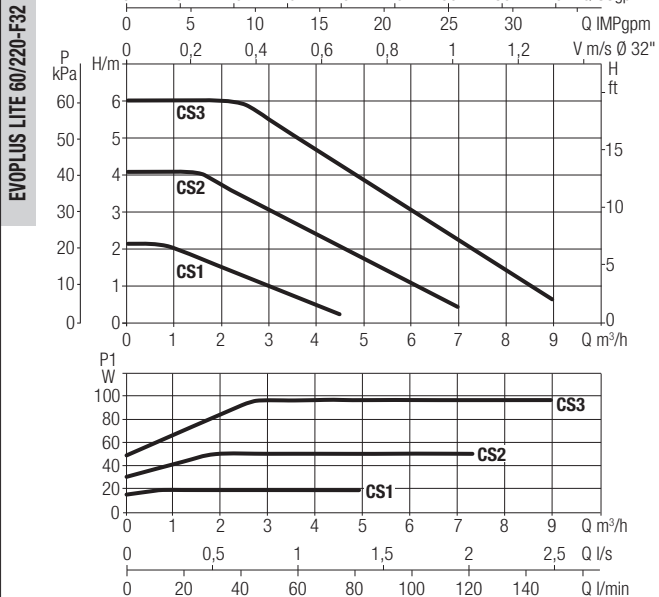
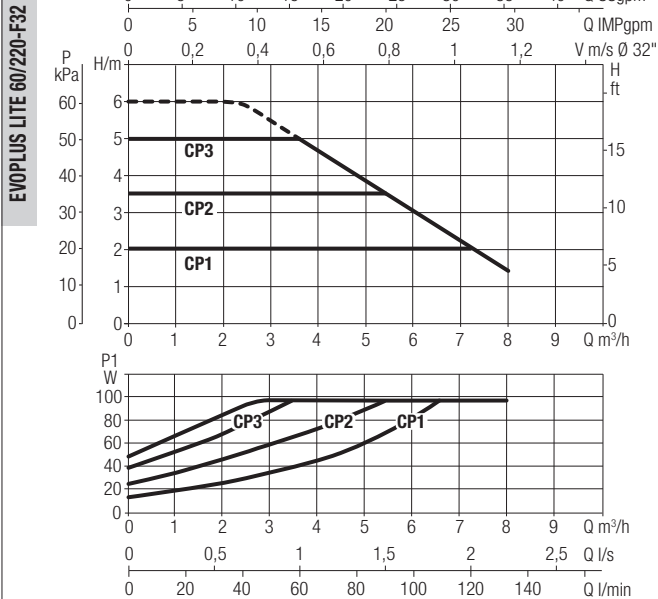
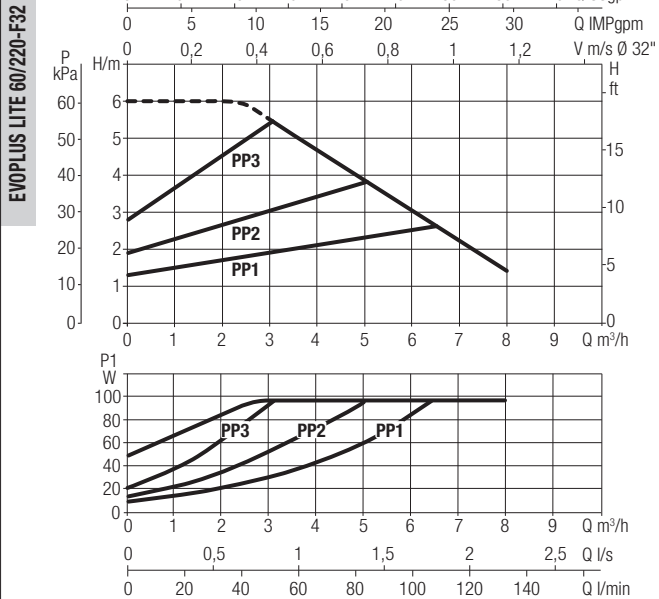

PPx = Proportional Differential Pressure - curve x
CPx = Constant Differential Pressure - curve x
CSx = Constant Speed - curve x

The curves are based on kinematic viscosity values = 1 mm²/s and density equal to 1000 kg/m³. Curve tolerance according to ISO 9906. Fixed speed curves available on the DNA.

MODEL	CENTRE DISTANCE mm	COUNTERFLANGES ON REQUEST	POWER INPUT 50/60 Hz	P1 MAX W	In A	EEI*	MINIMUM SUCTION PRESSURE			Q.TY x PALLET	WEIGHT Kg
							t°	90°	100°		
EVOPLUS LITE 60/220-F32	220	DN32 PN 6	220/240 V	97	0,78	EEI ≤ 0,20	m.c.w	20	25	64	6,3

* The parameter of reference for the more efficient circulators is EEI ≤ 0,20.

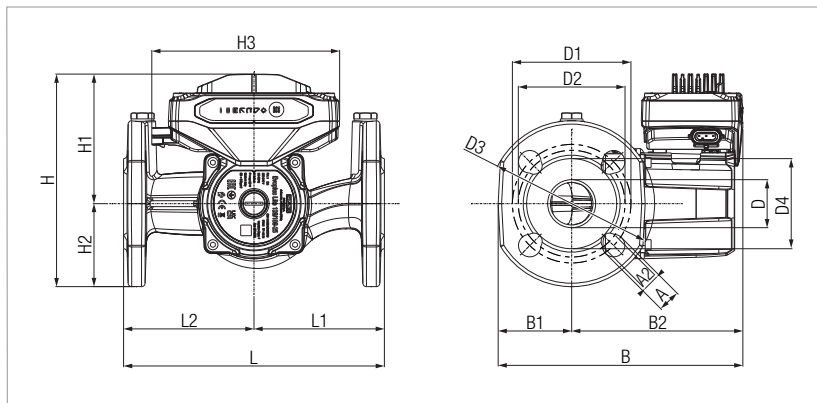

A1	A2	B	B1	B2	D
19	14	205	67	138	40

D1	D2	D3	D4	H	H1
100	90	140	76	179	109

H2	H3	L	L1	L2
70	159	220	110	110

EVOPLUS LITE 60/250-F40 - WET ROTOR ELECTRONIC CIRCULATORS

Pumped liquid temperature range: from -20°C up to +110°C - Maximum operating pressure: 16 bar (1600 kPa)

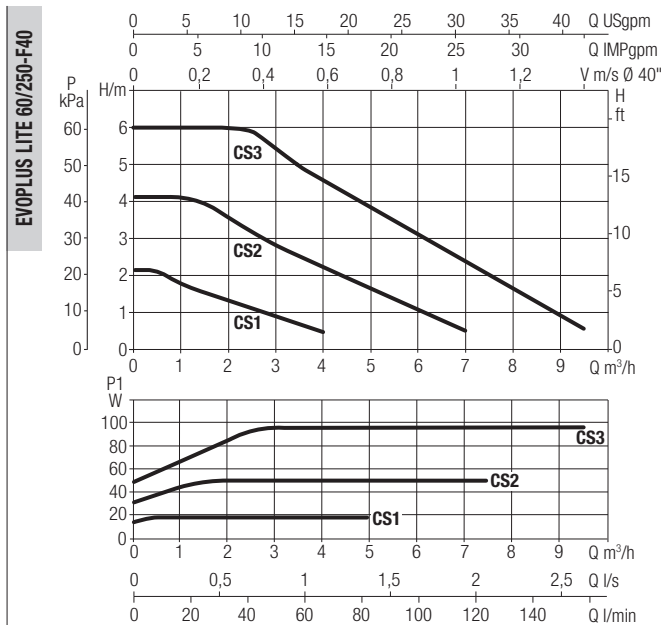
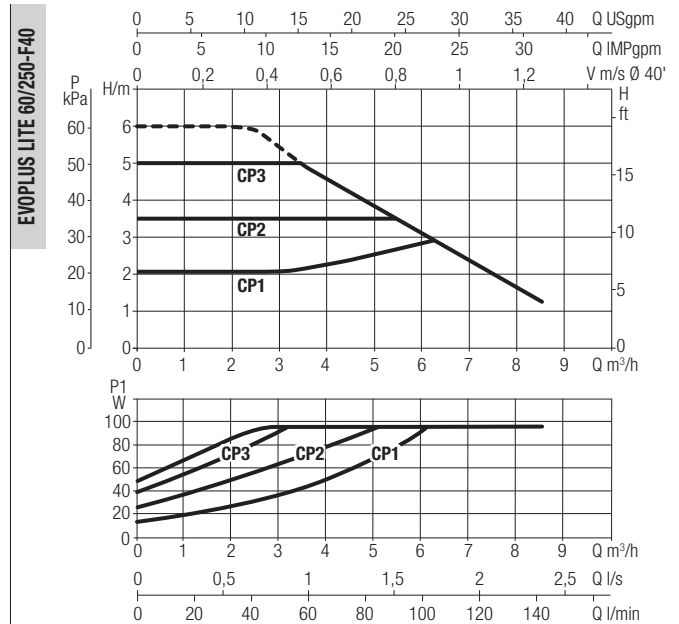
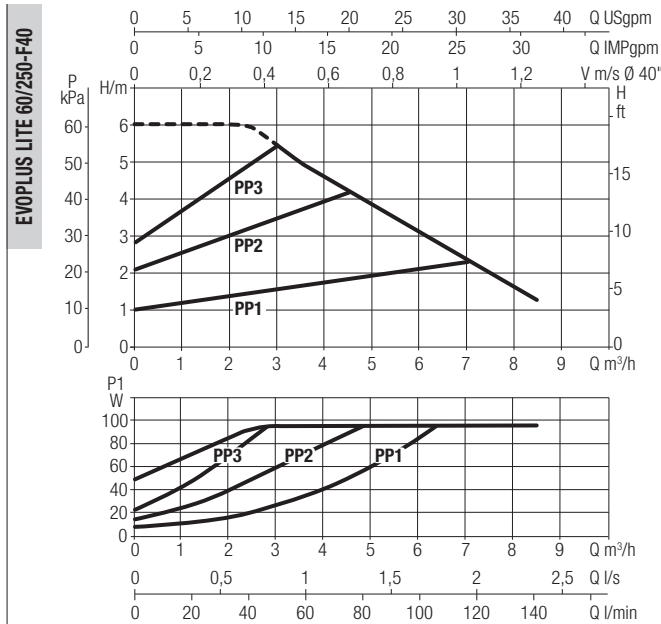

PPx = Proportional Differential Pressure - curve x
CPx = Constant Differential Pressure - curve x
CSx = Constant Speed - curve x

The curves are based on kinematic viscosity values = 1 mm²/s and density equal to 1000 kg/m³. Curve tolerance according to ISO 9906. Fixed speed curves available on the DNA.

MODEL	CENTRE DISTANCE mm	COUNTERFLANGES ON REQUEST	POWER INPUT 50/60 Hz	P1 MAX W	In A	EEI*	MINIMUM SUCTION PRESSURE			Q.TY x PALLET	WEIGHT Kg
							t°	90°	100°		
EVOPLUS LITE 60/250-F40	250	DN40 PN 10	220/240 V	97	0,78	EEI ≤ 0,21	m.c.w	20	25	64	6,7

* The parameter of reference for the more efficient circulators is EEI ≤ 0,20.

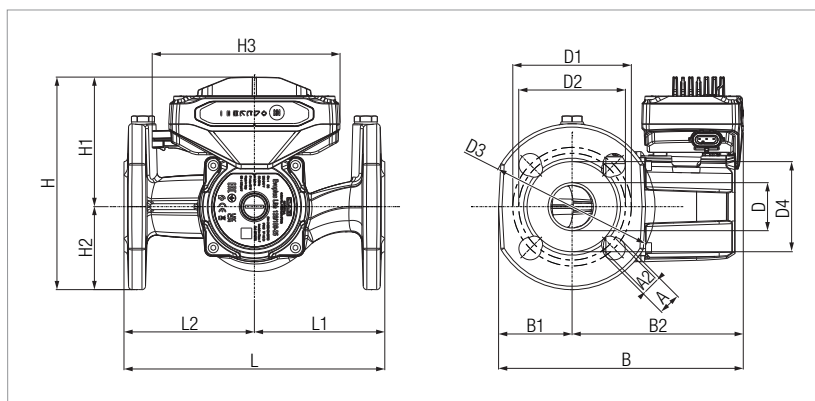

A1	A2	B	B1	B2	D
19	14	201	74	127	43

D1	D2	D3	D4	H	H1
110	100	150	84	184	109

H2	H3	L	L1	L2
75	159	250	125	125

EVOPLUS LITE 80/180-25 - WET ROTOR ELECTRONIC CIRCULATORS

Pumped liquid temperature range: from -20°C up to +110°C - Maximum operating pressure: 16 bar (1600 kPa)

EVOPLUS LITE 80/180-25

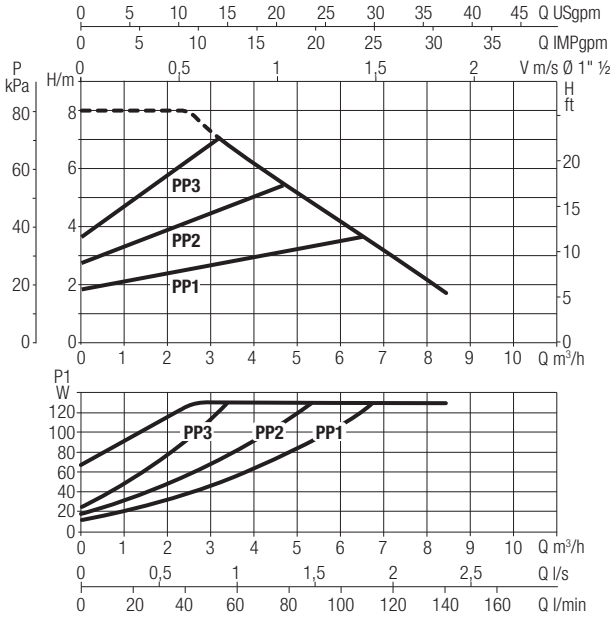

EVOPLUS LITE 80/180-25

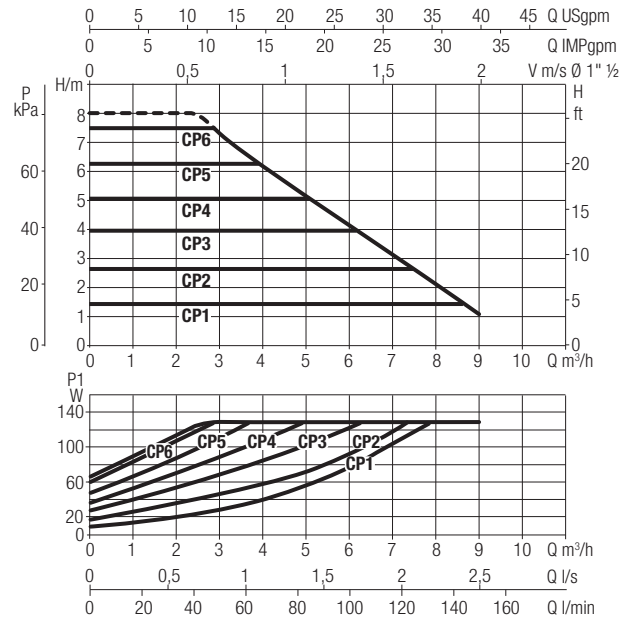

EVOPLUS LITE 80/180-25

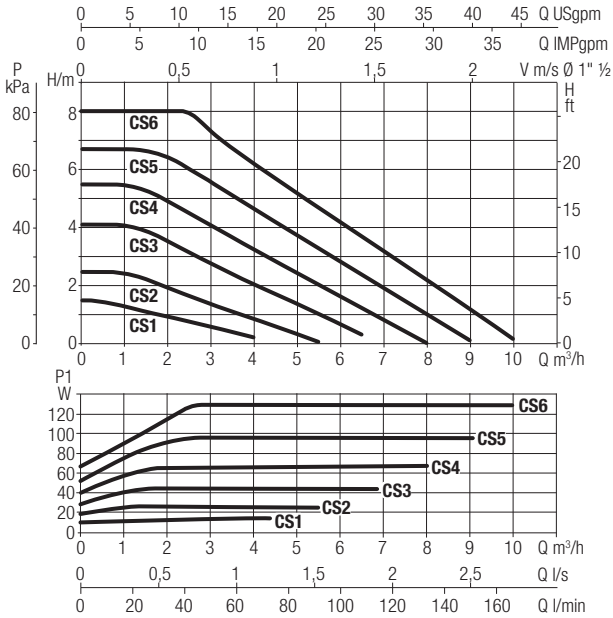

- PPx** = Proportional Differential Pressure - curve x
- CPx** = Constant Differential Pressure - curve x
- CSx** = Constant Speed - curve x

The curves are based on kinematic viscosity values = 1 mm²/s and density equal to 1000 kg/m³. Curve tolerance according to ISO 9906. Fixed speed curves available on the DNA.

MODEL	CENTRE DISTANCE mm	COUNTERFLANGES ON REQUEST	POWER INPUT 50/60 Hz	P1 MAX W	In A	EEI*	MINIMUM SUCTION PRESSURE			Q.TY x PALLET	WEIGHT Kg
							t°	90°	100°		
EVOPLUS LITE 80/180-25	180	-	220/240 V	129	1,04	EEI ≤ 0,20	m.c.w	20	25	92	3,4

* The parameter of reference for the more efficient circulators is EEI ≤ 0,20.

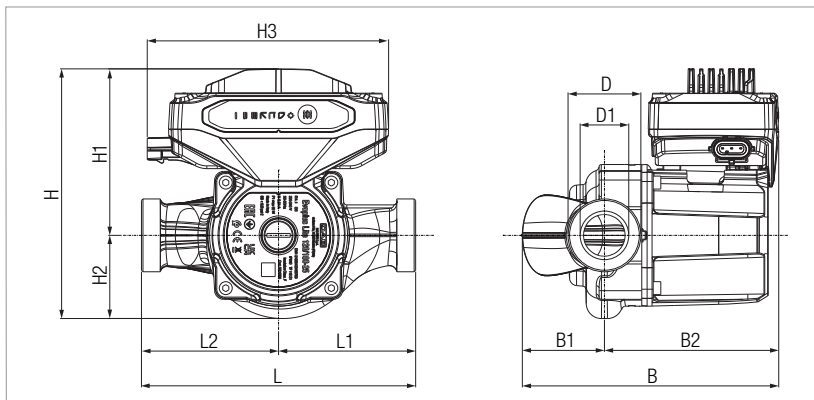

B	B1	B2	D	D1	H
168	54	114	1½"	32	164

H1	H2	H3	L	L1	L2
109	55	159	180	90	90

EVOPLUS LITE 80/180-32 - WET ROTOR ELECTRONIC CIRCULATORS

Pumped liquid temperature range: from -20°C up to +110°C - Maximum operating pressure: 16 bar (1600 kPa)

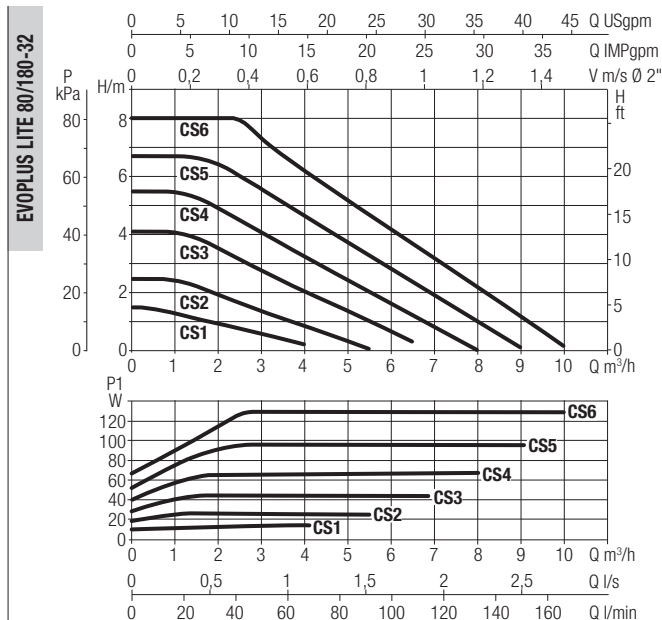
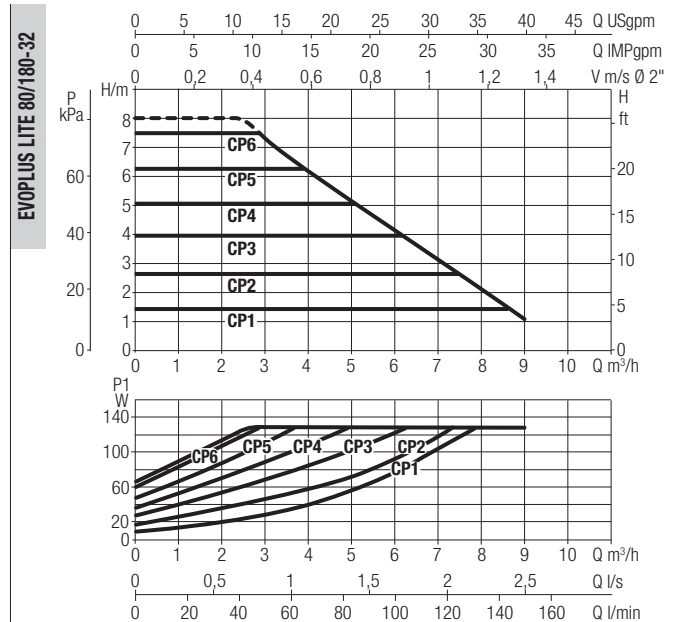
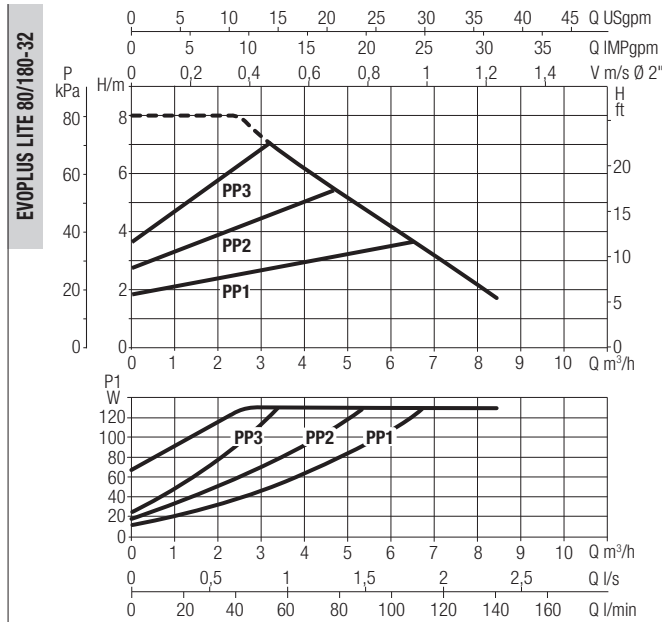

PPx = Proportional Differential Pressure - curve x
CPx = Constant Differential Pressure - curve x
CSx = Constant Speed - curve x

The curves are based on kinematic viscosity values = 1 mm²/s and density equal to 1000 kg/m³. Curve tolerance according to ISO 9906. Fixed speed curves available on the DNA.

MODEL	CENTRE DISTANCE mm	COUNTERFLANGES ON REQUEST	POWER INPUT 50/60 Hz	P1 MAX W	In A	EEI*	MINIMUM SUCTION PRESSURE			Q.TY x PALLET	WEIGHT Kg
							t°	90°	100°		
EVOPLUS LITE 80/180-32	180	-	220/240 V	129	1,04	EEI ≤ 0,21	m.c.w	20	25	92	3,5

* The parameter of reference for the more efficient circulators is EEI ≤ 0,20.

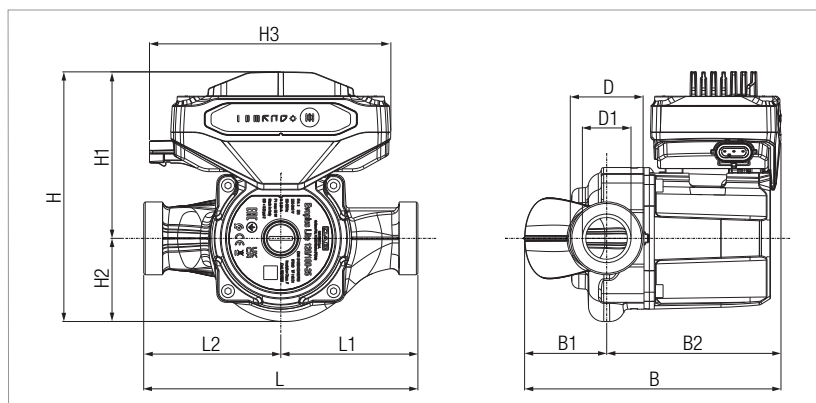

B	B1	B2	D	D1	H
168	54	114	2"	32	164

H1	H2	H3	L	L1	L2
109	55	159	180	90	90

EVOPLUS LITE 80/220-F32 - WET ROTOR ELECTRONIC CIRCULATORS

Pumped liquid temperature range: from -20°C up to +110°C - Maximum operating pressure: 16 bar (1600 kPa)

EVOPLUS LITE 80/220-F32

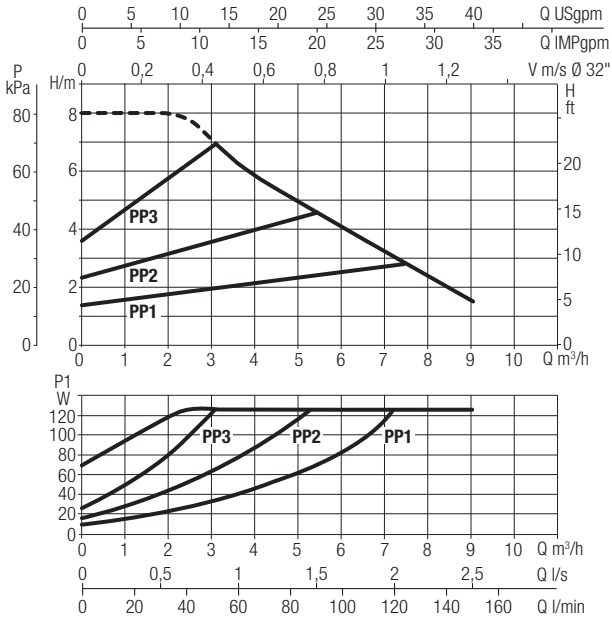

EVOPLUS LITE 80/220-F32

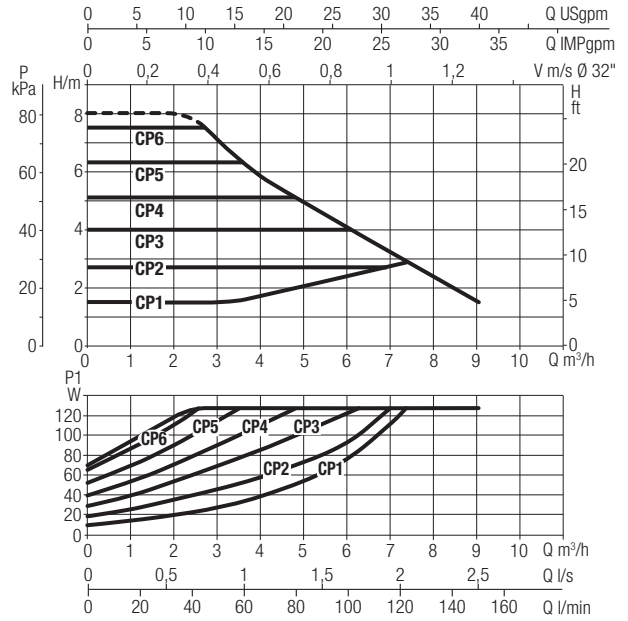

EVOPLUS LITE 80/220-F32

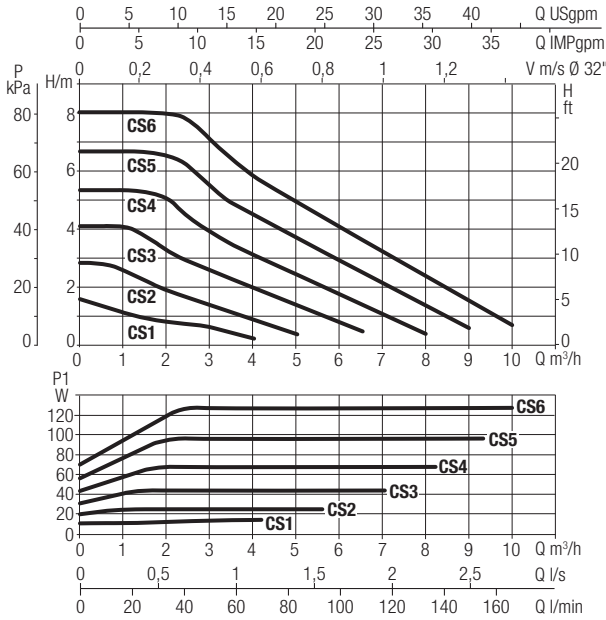

PPx = Proportional Differential Pressure - curve x
CPx = Constant Differential Pressure - curve x
CSx = Constant Speed - curve x

The curves are based on kinematic viscosity values = 1 mm²/s and density equal to 1000 kg/m³. Curve tolerance according to ISO 9906. Fixed speed curves available on the DNA.

MODEL	CENTRE DISTANCE mm	COUNTERFLANGES ON REQUEST	POWER INPUT 50/60 Hz	P1 MAX W	In A	EEI*	MINIMUM SUCTION PRESSURE			Q.TY x PALLET	WEIGHT Kg
							t°	90°	100°		
EVOPLUS LITE 80/220-F32	220	DN32 PN 6	220/240 V	127	1,04	EEI ≤ 0,21	m.c.w	20	25	64	6,3

* The parameter of reference for the more efficient circulators is EEI ≤ 0,20.

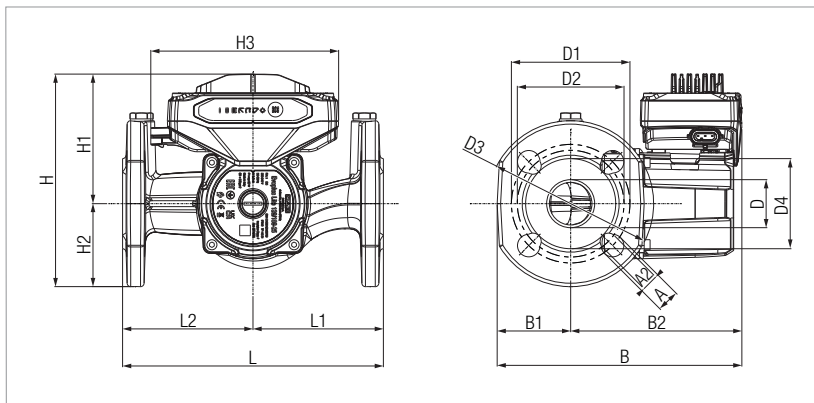

A1	A2	B	B1	B2	D
19	14	205	67	138	40

D1	D2	D3	D4	H	H1
100	90	140	76	179	109

H2	H3	L	L1	L2
70	159	220	110	110

EVOPLUS LITE 80/250-F40 - WET ROTOR ELECTRONIC CIRCULATORS

Pumped liquid temperature range: from -20°C up to +110°C - Maximum operating pressure: 16 bar (1600 kPa)

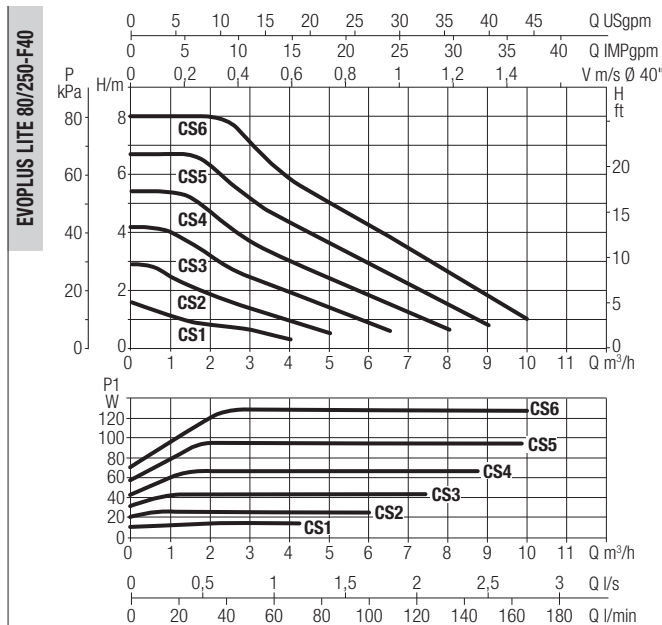
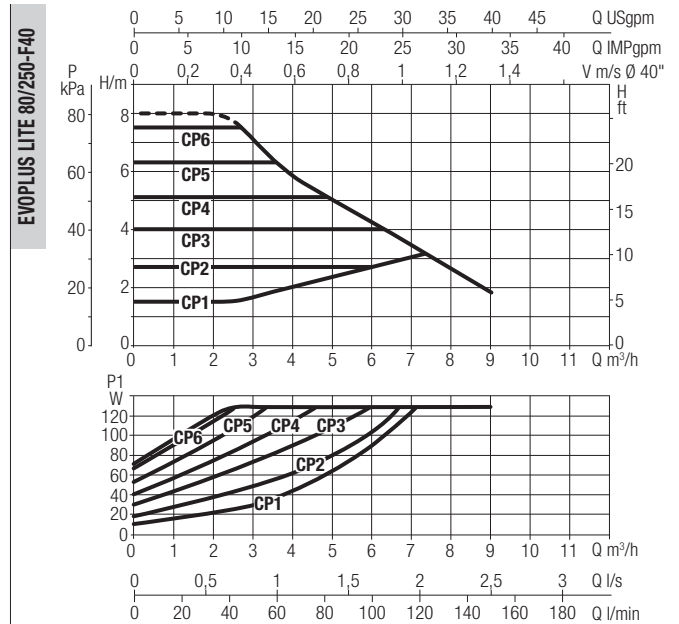
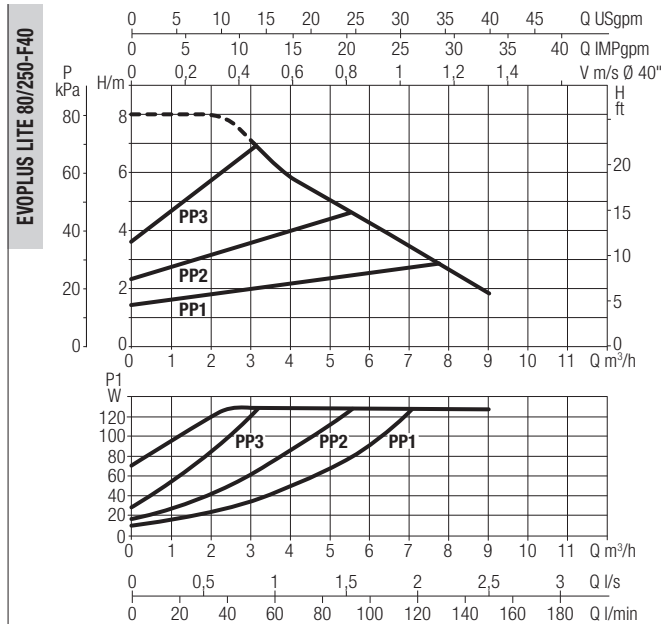

PPx = Proportional Differential Pressure - curve x
CPx = Constant Differential Pressure - curve x
CSx = Constant Speed - curve x

The curves are based on kinematic viscosity values = 1 mm²/s and density equal to 1000 kg/m³. Curve tolerance according to ISO 9906. Fixed speed curves available on the DNA.

MODEL	CENTRE DISTANCE mm	COUNTERFLANGES ON REQUEST	POWER INPUT 50/60 Hz	P1 MAX W	In A	EEI*	MINIMUM SUCTION PRESSURE			Q.TY x PALLET	WEIGHT Kg
							t°	90°	100°		
EVOPLUS LITE 80/250-F40	250	DN40 PN 10	220/240 V	128	1,04	EEI ≤ 0,20	m.c.w	20	25	64	6,7

* The parameter of reference for the more efficient circulators is EEI ≤ 0,20.

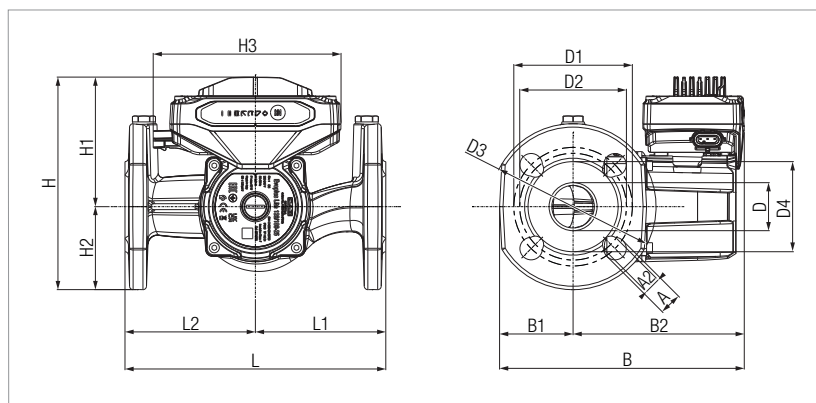

A1	A2	B	B1	B2	D
19	14	201	74	127	43

D1	D2	D3	D4	H	H1
110	100	150	84	184	109

H2	H3	L	L1	L2
75	159	250	125	125

EVOPLUS LITE 120/180-25 - WET ROTOR ELECTRONIC CIRCULATORS

Pumped liquid temperature range: from -20°C up to +110°C - Maximum operating pressure: 16 bar (1600 kPa)

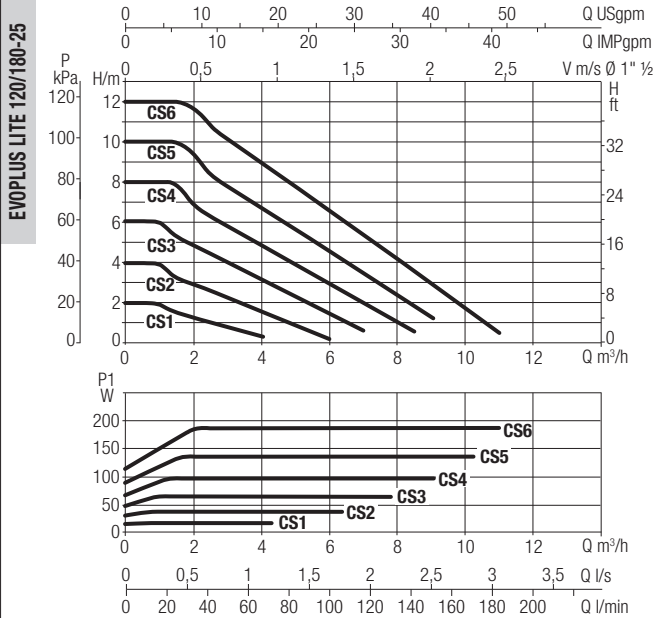
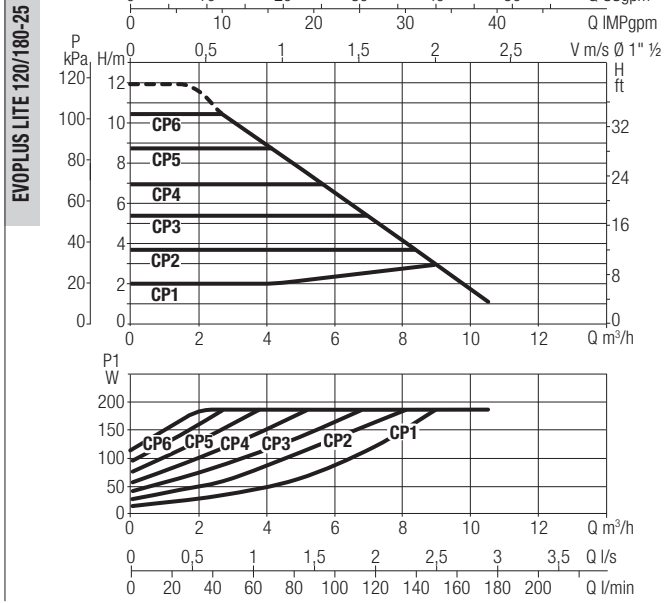
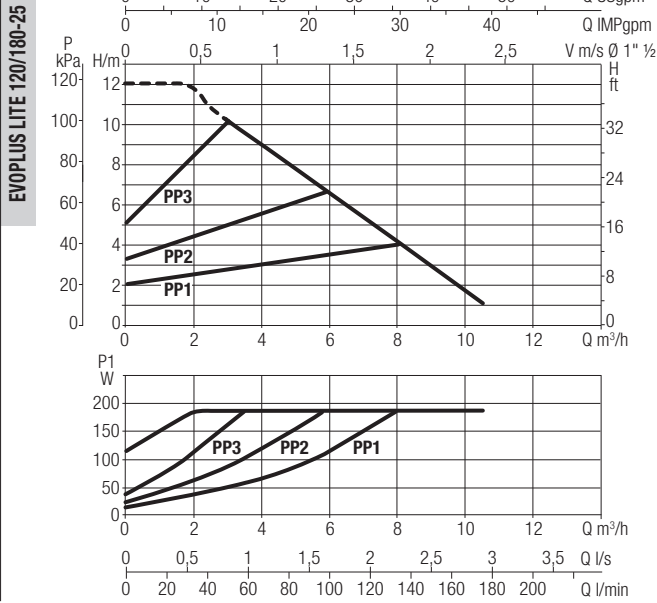

PPx = Proportional Differential Pressure - curve x
CPx = Constant Differential Pressure - curve x
CSx = Constant Speed - curve x

The curves are based on kinematic viscosity values = 1 mm²/s and density equal to 1000 kg/m³. Curve tolerance according to ISO 9906. Fixed speed curves available on the DNA.

MODEL	CENTRE DISTANCE mm	COUNTERFLANGES ON REQUEST	POWER INPUT 50/60 Hz	P1 MAX W	In A	EEI*	MINIMUM SUCTION PRESSURE			Q.TY x PALLET	WEIGHT Kg
							t°	90°	100°		
EVOPLUS LITE 120/180-25	180	-	220/240 V	187	1,49	EEI ≤ 0,20	m.c.w	20	25	92	3,4

* The parameter of reference for the more efficient circulators is EEI ≤ 0,20.

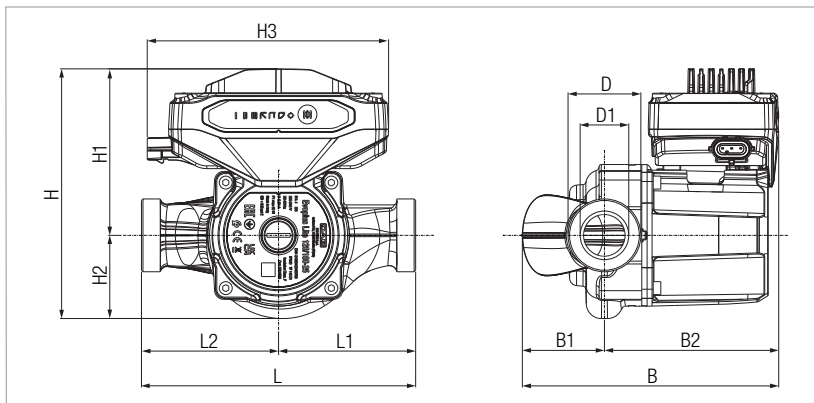

B	B1	B2	D	D1	H
168	54	114	1½"	32	164

H1	H2	H3	L	L1	L2
109	55	159	180	90	90

EVOPLUS LITE 120/180-32 - WET ROTOR ELECTRONIC CIRCULATORS

Pumped liquid temperature range: from -20°C up to +110°C - Maximum operating pressure: 16 bar (1600 kPa)

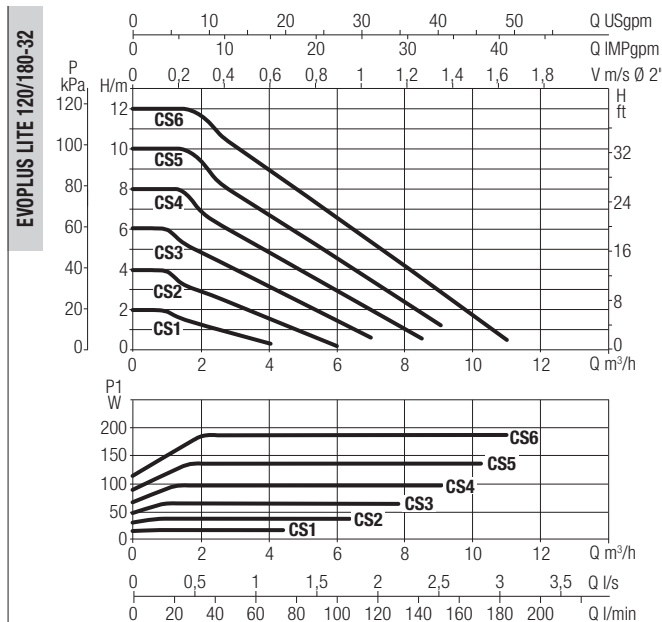
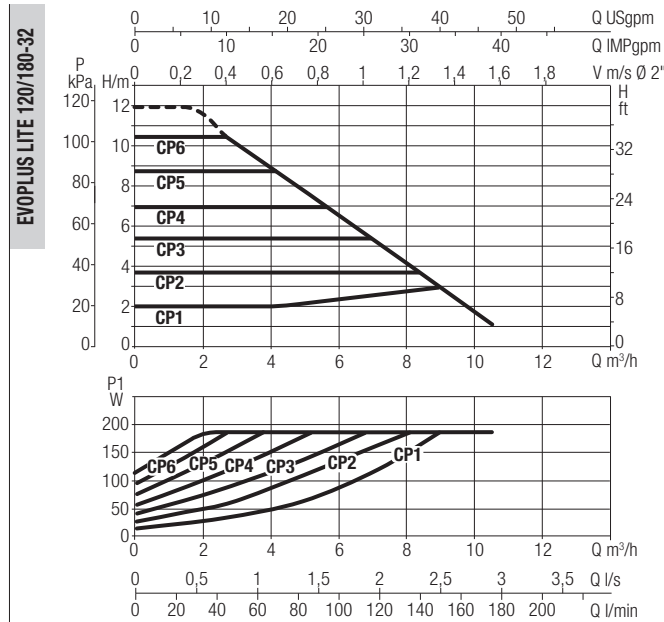
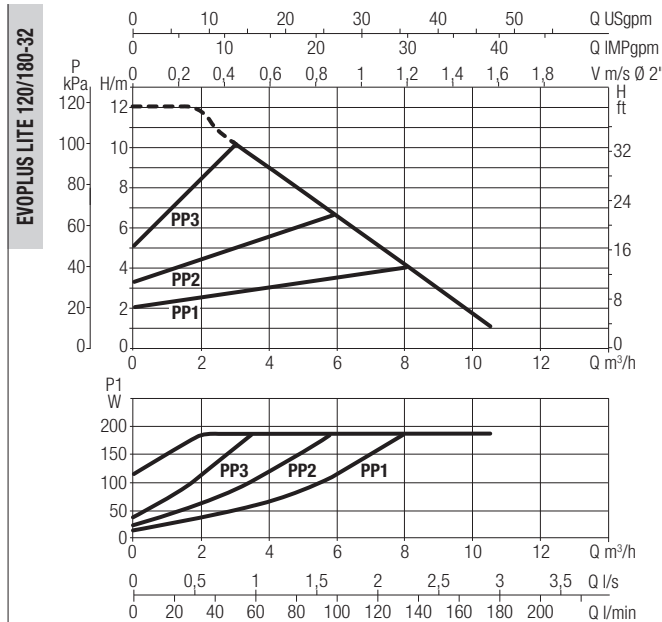

PPx = Proportional Differential Pressure - curve x
CPx = Constant Differential Pressure - curve x
CSx = Constant Speed - curve x

The curves are based on kinematic viscosity values = 1 mm²/s and density equal to 1000 kg/m³. Curve tolerance according to ISO 9906. Fixed speed curves available on the DNA.

MODEL	CENTRE DISTANCE mm	COUNTERFLANGES ON REQUEST	POWER INPUT 50/60 Hz	P1 MAX W	In A	EEI*	MINIMUM SUCTION PRESSURE			Q.TY x PALLET	WEIGHT Kg
							t°	90°	100°		
EVOPLUS LITE 120/180-32	180	-	220/240 V	187	1,49	EEI ≤ 0,20	m.c.w	20	25	92	3,5

* The parameter of reference for the more efficient circulators is EEI ≤ 0,20.

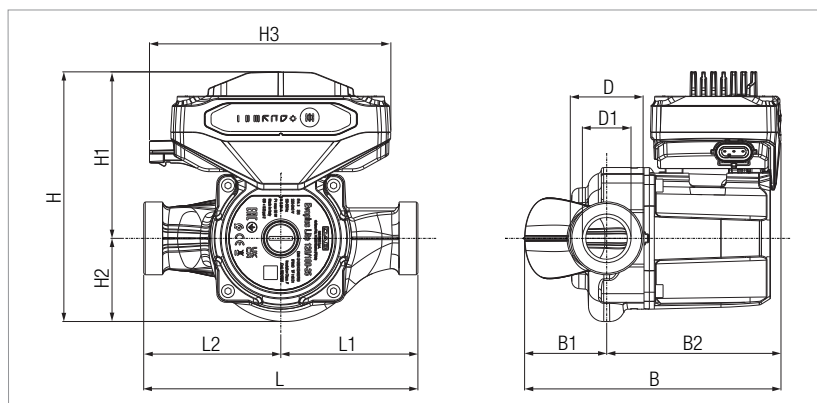

B	B1	B2	D	D1	H
168	54	114	2"	32	164

H1	H2	H3	L	L1	L2
109	55	159	180	90	90

EVOPLUS LITE 120/220-F32- WET ROTOR ELECTRONIC CIRCULATORS

Pumped liquid temperature range: from -20°C up to +110°C - Maximum operating pressure: 16 bar (1600 kPa)

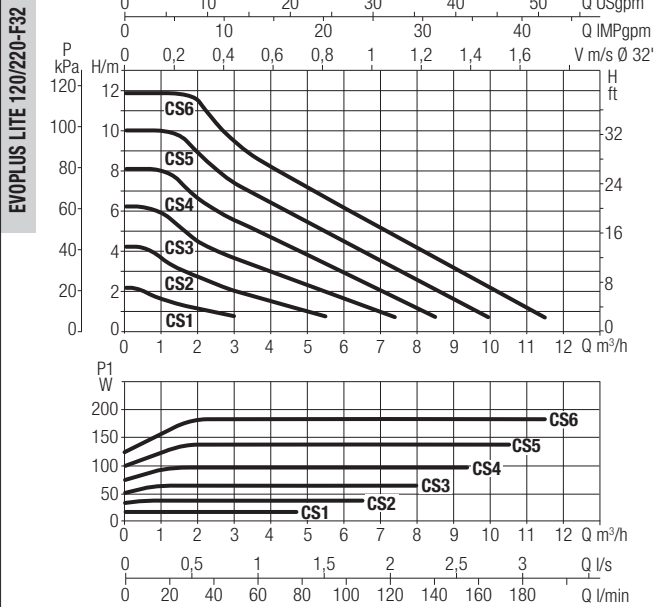
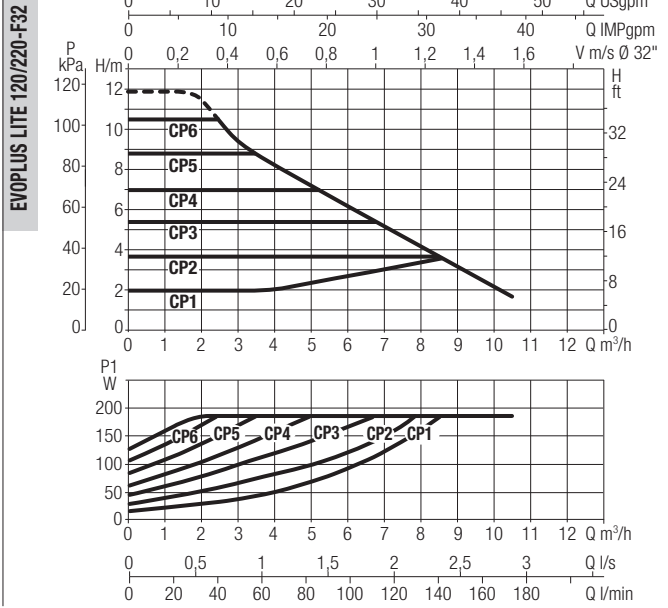
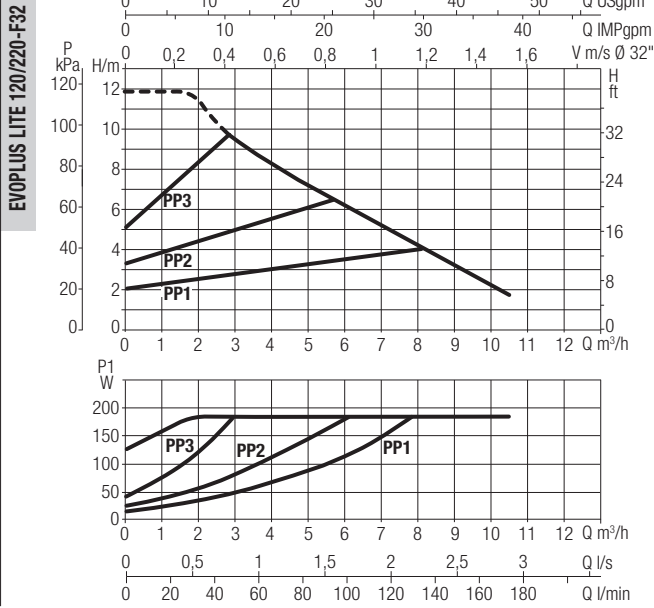

PPx = Proportional Differential Pressure - curve x
CPx = Constant Differential Pressure - curve x
CSx = Constant Speed - curve x

The curves are based on kinematic viscosity values = 1 mm²/s and density equal to 1000 kg/m³. Curve tolerance according to ISO 9906. Fixed speed curves available on the DNA.

MODEL	CENTRE DISTANCE mm	COUNTERFLANGES ON REQUEST	POWER INPUT 50/60 Hz	P1 MAX W	In A	EEI*	MINIMUM SUCTION PRESSURE			Q.TY x PALLET	WEIGHT Kg
							t°	90°	100°		
EVOPLUS LITE 120/220-F32	220	DN32 PN 6	220/240 V	185	1,49	EEI ≤ 0,21	m.c.w	20	25	64	6,3

* The parameter of reference for the more efficient circulators is EEI ≤ 0,20.

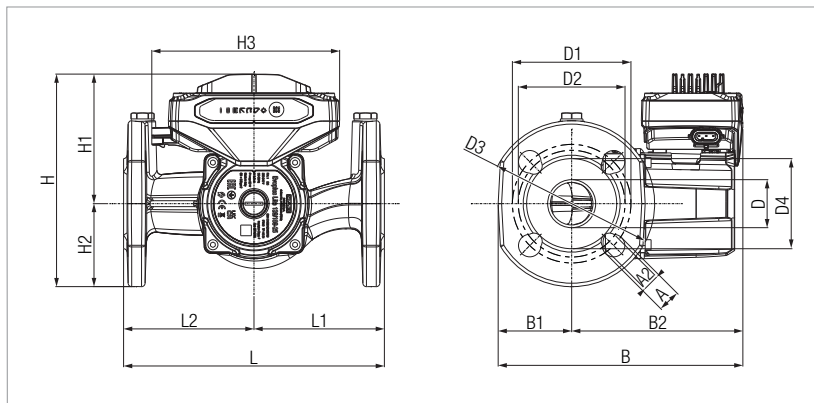

A1	A2	B	B1	B2	D
19	14	205	67	138	40

D1	D2	D3	D4	H	H1
100	90	140	76	179	109

H2	H3	L	L1	L2
70	159	220	110	110

EVOPLUS LITE 120/250-F40 - WET ROTOR ELECTRONIC CIRCULATORS

Pumped liquid temperature range: from -20°C up to +110°C - Maximum operating pressure: 16 bar (1600 kPa)

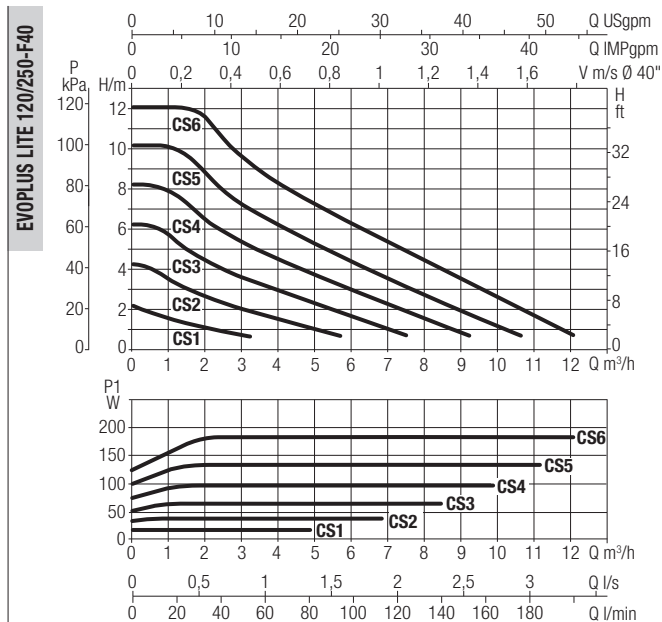
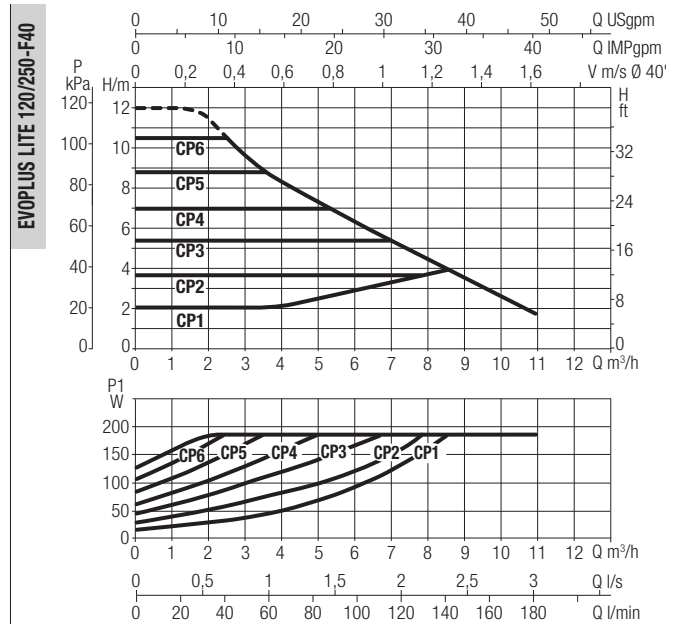
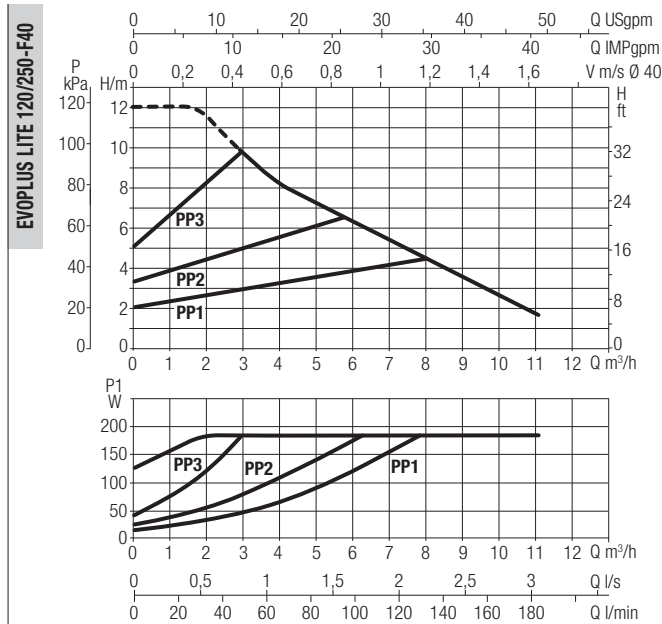

PPx = Proportional Differential Pressure - curve x

CPx = Constant Differential Pressure - curve x

CSx = Constant Speed - curve x

The curves are based on kinematic viscosity values = 1 mm²/s and density equal to 1000 kg/m³. Curve tolerance according to ISO 9906. Fixed speed curves available on the DNA.

MODEL	CENTRE DISTANCE mm	COUNTERFLANGES ON REQUEST	POWER INPUT 50/60 Hz	P1 MAX W	In A	EEI*	MINIMUM SUCTION PRESSURE			Q.TY x PALLET	WEIGHT Kg
							t°	90°	100°		
EVOPLUS LITE 120/250-F40	250	DN40 PN 10	220/240 V	186	1,49	EEI ≤ 0,21	m.c.w	20	25	64	6,7

* The parameter of reference for the more efficient circulators is EEI ≤ 0,20.

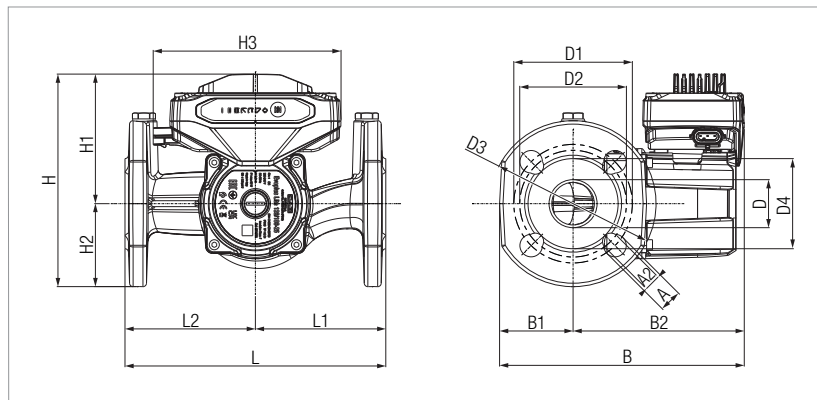

A1	A2	B	B1	B2	D
19	14	201	74	127	43

D1	D2	D3	D4	H	H1
110	100	150	84	184	109

H2	H3	L	L1	L2
75	159	250	125	125

EVOPLUS LITE SAN 60/180-25 - WET ROTOR ELECTRONIC CIRCULATORS

Pumped liquid temperature range: from -20°C up to +110°C - Maximum operating pressure: 16 bar (1600 kPa)

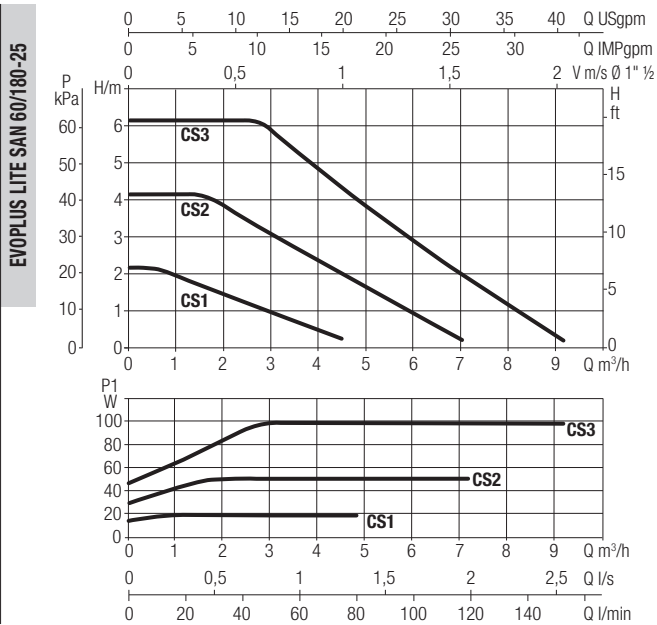
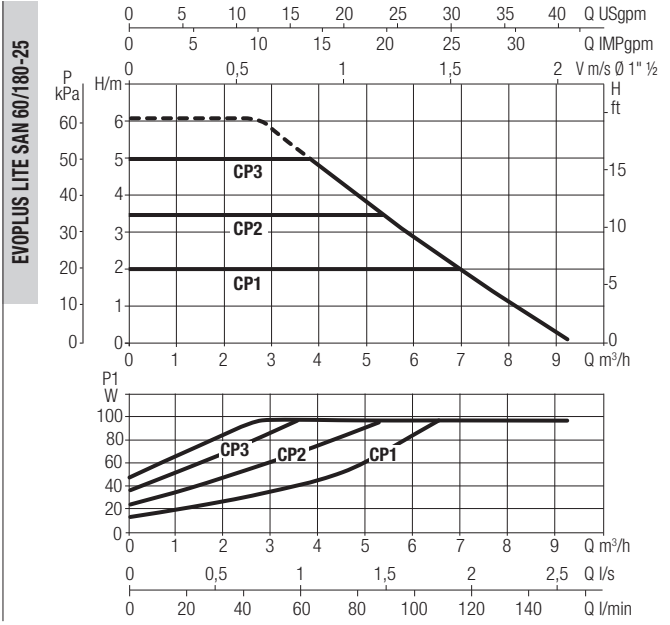
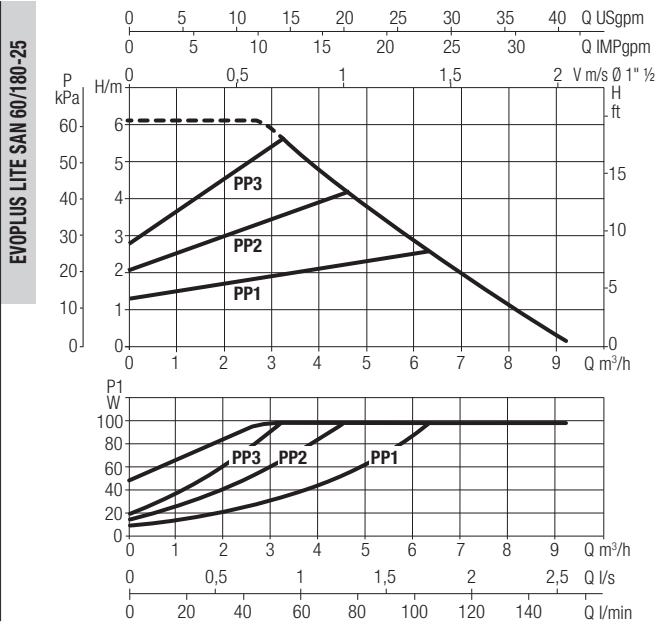

PPx = Proportional Differential Pressure - curve x
CPx = Constant Differential Pressure - curve x
CSx = Constant Speed - curve x

The curves are based on kinematic viscosity values = 1 mm²/s and density equal to 1000 kg/m³. Curve tolerance according to ISO 9906. Fixed speed curves available on the DNA.

MODEL	CENTRE DISTANCE mm	COUNTERFLANGES ON REQUEST	POWER INPUT 50/60 Hz	P1 MAX W	I _n A	EEI*	MINIMUM SUCTION PRESSURE			Q.TY x PALLET	WEIGHT Kg
							t°	90°	100°		
EVOPLUS LITE SAN 60/180-25	180	-	220/240 V	98	0,78	EEI ≤ 0,20	m.c.w	20	25	92	3,4

* The parameter of reference for the more efficient circulators is EEI ≤ 0,20.

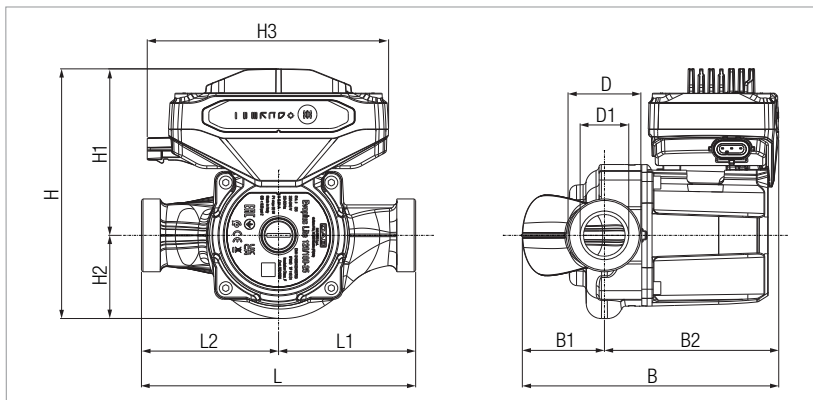

B	B1	B2	D	D1	H
168	54	114	1 1/2	32	164

H1	H2	H3	L	L1	L2
109	55	159	180	90	90

EVOPLUS LITE SAN 60/220-F32 - WET ROTOR ELECTRONIC CIRCULATORS

Pumped liquid temperature range: from -20°C up to +110°C - Maximum operating pressure: 16 bar (1600 kPa)

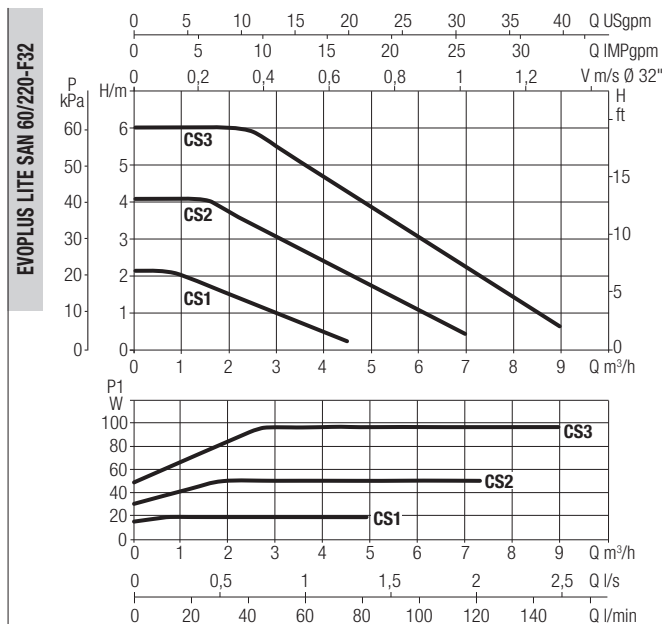
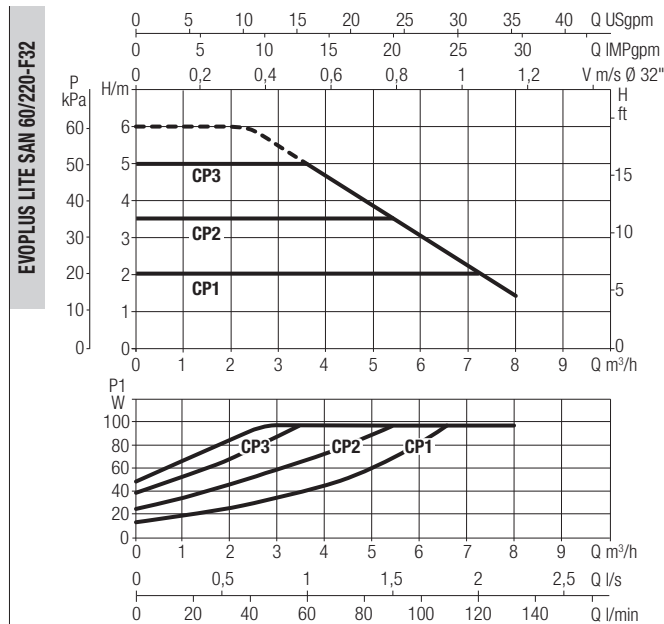
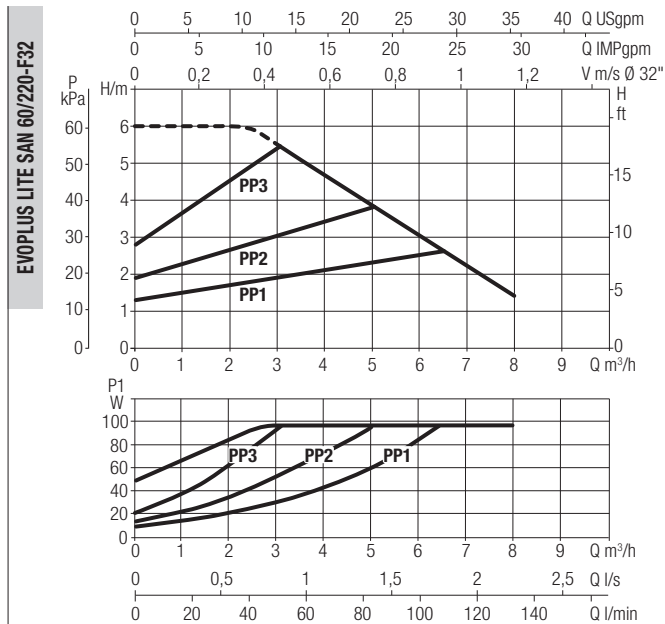

PPx = Proportional Differential Pressure - curve x
CPx = Constant Differential Pressure - curve x
CSx = Constant Speed - curve x

The curves are based on kinematic viscosity values = 1 mm²/s and density equal to 1000 kg/m³. Curve tolerance according to ISO 9906. Fixed speed curves available on the DNA.

MODEL	CENTRE DISTANCE mm	COUNTERFLANGES ON REQUEST	POWER INPUT 50/60 Hz	P1 MAX W	In A	EEI*	MINIMUM SUCTION PRESSURE			Q.TY X PALLET	WEIGHT Kg
							t°	90°	100°		
EVOPLUS LITE SAN 60/220-F32	220	DN 32 PN 6	220/240 V	97	0,78	EEI ≤ 0,20	m.c.w	20	25	64	7,2

* The parameter of reference for the more efficient circulators is EEI ≤ 0,20.

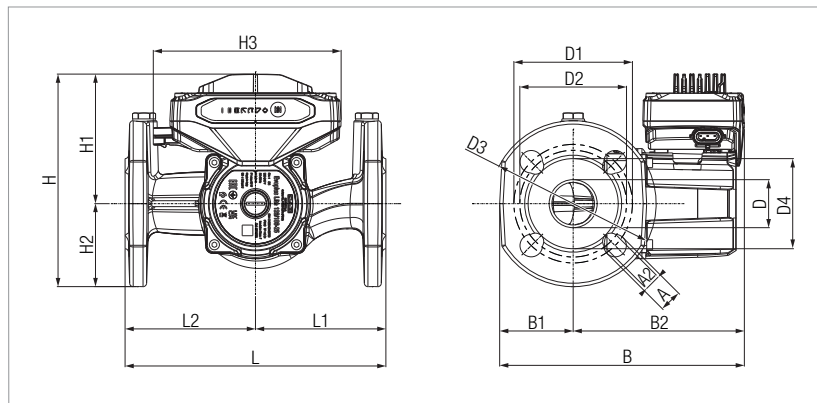

A1	A2	B	B1	B2	D
19	14	205	67	138	40

D1	D2	D3	D4	H	H1
100	90	140	76	179	109

H2	H3	L	L1	L2
70	159	220	110	110

EVOPLUS LITE SAN 60/250-F40 - WET ROTOR ELECTRONIC CIRCULATORS

Pumped liquid temperature range: from -20°C up to +110°C - Maximum operating pressure: 16 bar (1600 kPa)

EVOPLUS LITE SAN 60/250-F40

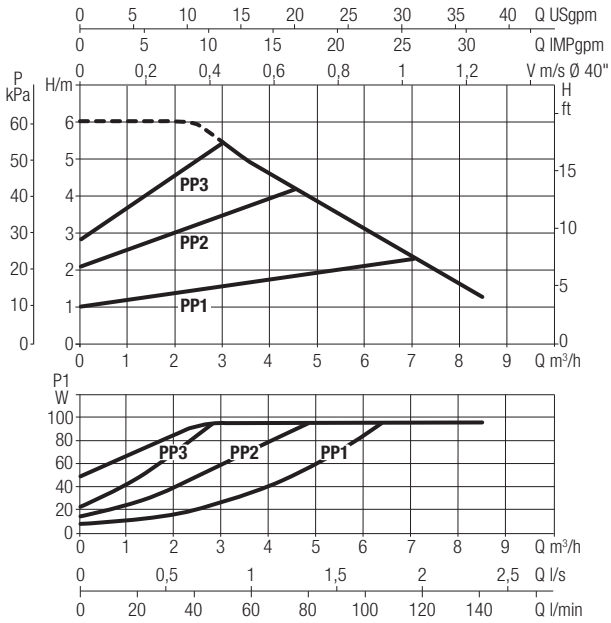

EVOPLUS LITE SAN 60/250-F40

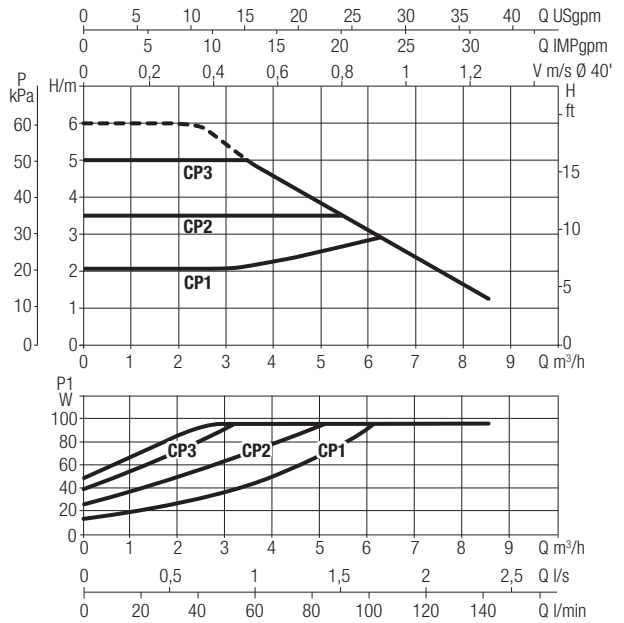

EVOPLUS LITE SAN 60/250-F40

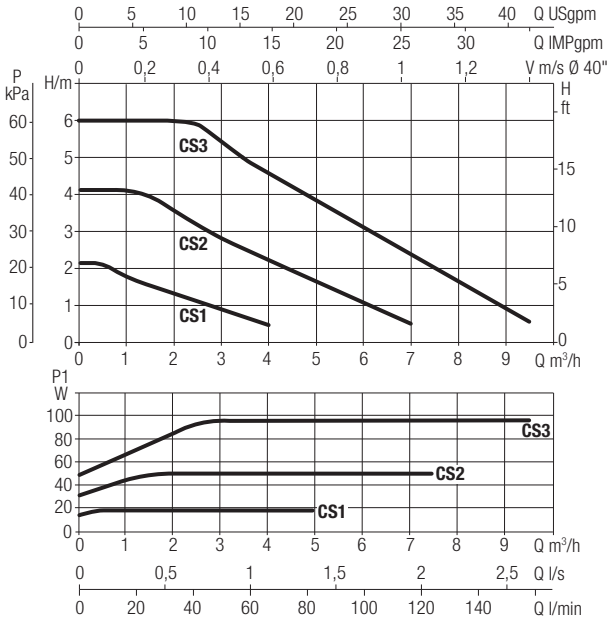

PPx = Proportional Differential Pressure - curve x
CPx = Constant Differential Pressure - curve x
CSx = Constant Speed - curve x

The curves are based on kinematic viscosity values = 1 mm²/s and density equal to 1000 kg/m³. Curve tolerance according to ISO 9906. Fixed speed curves available on the DNA.

MODEL	CENTRE DISTANCE mm	COUNTERFLANGES ON REQUEST	POWER INPUT 50/60 Hz	P1 MAX W	In A	EEI*	MINIMUM SUCTION PRESSURE			Q.TY x PALLET	WEIGHT Kg
							t°	90°	100°		
EVOPLUS LITE SAN 60/250-F40	250	DN 40 PN 10	220/240 V	97	0,78	EEI ≤ 0,21	m.c.w	20	25	64	7,7

* The parameter of reference for the more efficient circulators is EEI ≤ 0,20.

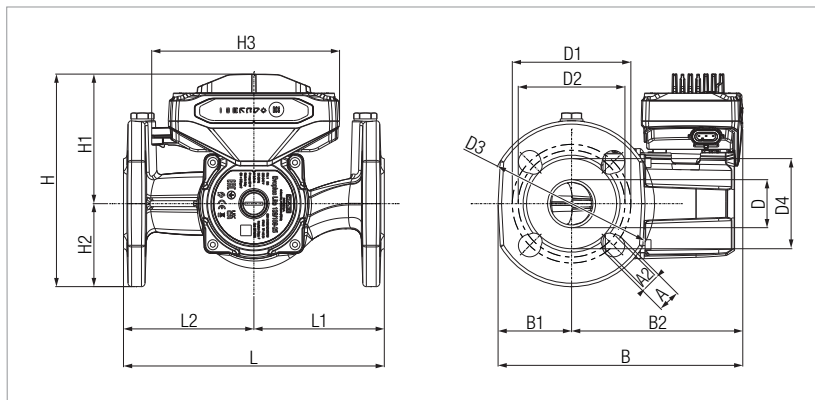

A1	A2	B	B1	B2	D
19	14	201	74	127	43

D1	D2	D3	D4	H	H1
110	100	150	84	184	109

H2	H3	L	L1	L2
75	159	250	125	125

EVOPLUS LITE SAN 80/180-25 - WET ROTOR ELECTRONIC CIRCULATORS

Pumped liquid temperature range: from -20°C up to +110°C - Maximum operating pressure: 16 bar (1600 kPa)

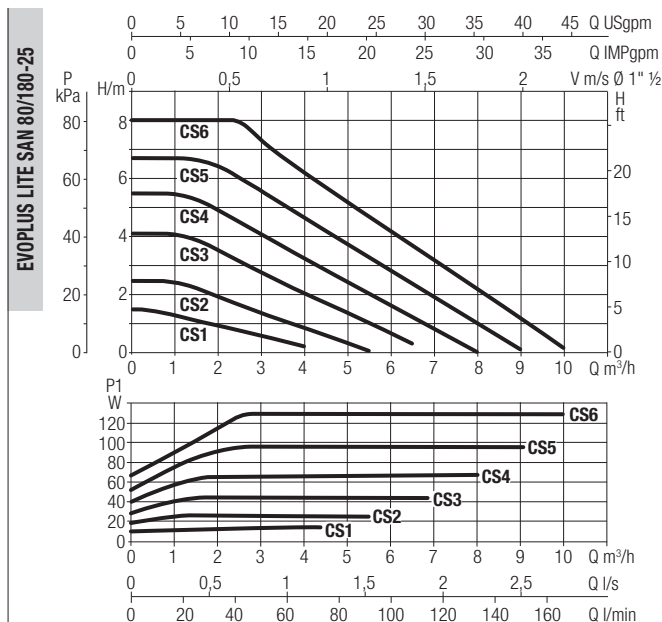
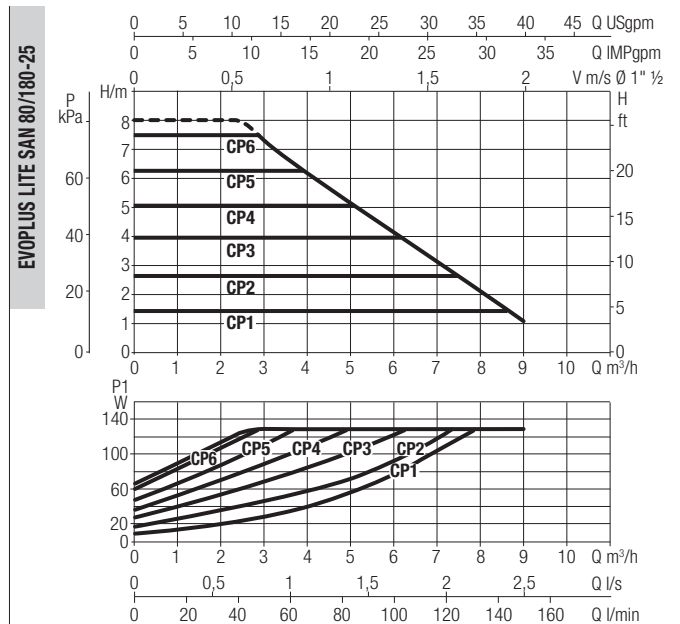
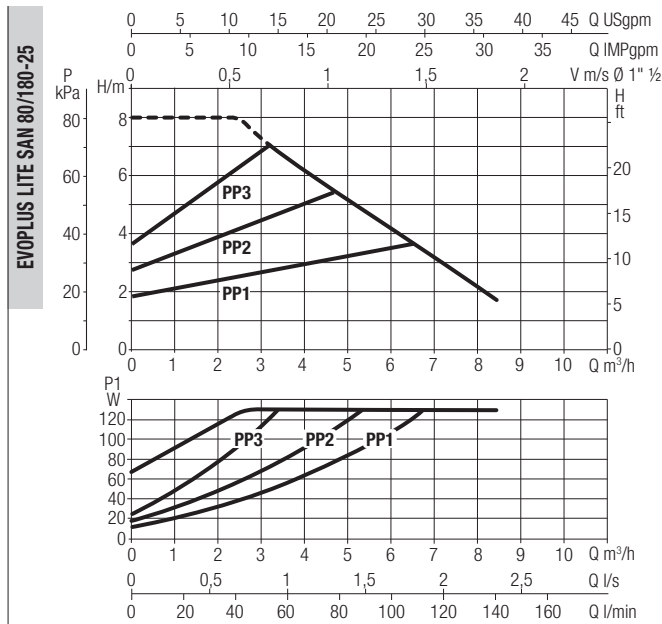

PPx = Proportional Differential Pressure - curve x
CPx = Constant Differential Pressure - curve x
CSx = Constant Speed - curve x

The curves are based on kinematic viscosity values = 1 mm²/s and density equal to 1000 kg/m³. Curve tolerance according to ISO 9906. Fixed speed curves available on the DNA.

MODEL	CENTRE DISTANCE mm	COUNTERFLANGES ON REQUEST	POWER INPUT 50/60 Hz	P1 MAX W	In A	EEI*	MINIMUM SUCTION PRESSURE			Q.TY x PALLET	WEIGHT Kg
							t°	90°	100°		
EVOPLUS LITE SAN 80/180-25	180	-	220/240 V	129	1,04	EEI ≤ 0,20	m.c.w	20	25	92	3,7

* The parameter of reference for the more efficient circulators is EEI ≤ 0,20.

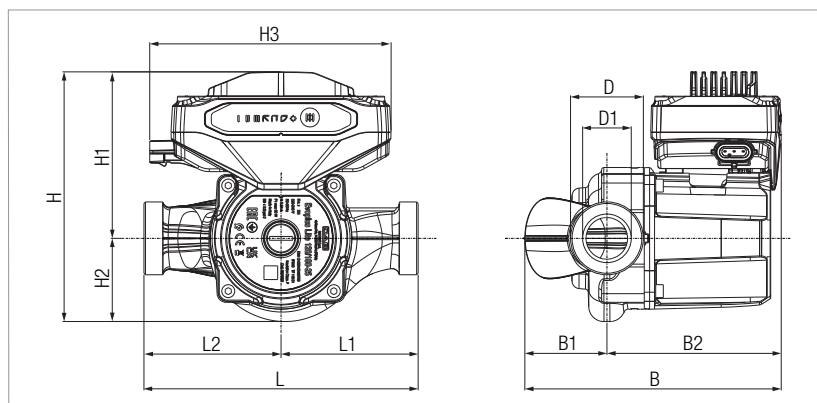

B	B1	B2	D	D1	H
168	54	114	1½"	32	164

H1	H2	H3	L	L1	L2
109	55	159	180	90	90

EVOPLUS LITE SAN 80/220-F32 - WET ROTOR ELECTRONIC CIRCULATORS

Pumped liquid temperature range: from -20°C up to +110°C - Maximum operating pressure: 16 bar (1600 kPa)

EVOPLUS LITE SAN 80/220-F32

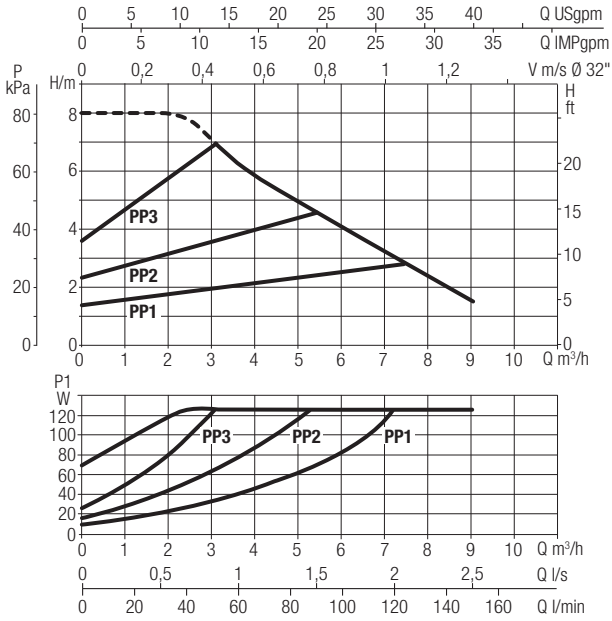

EVOPLUS LITE SAN 80/220-F32

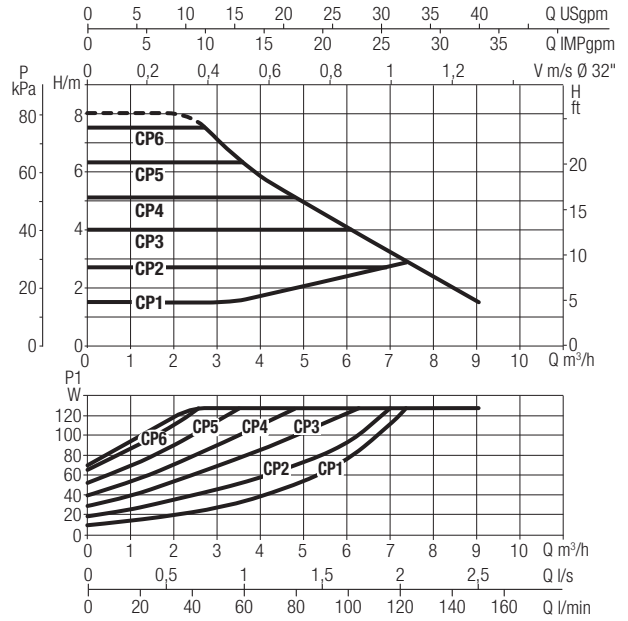

EVOPLUS LITE SAN 80/220-F32

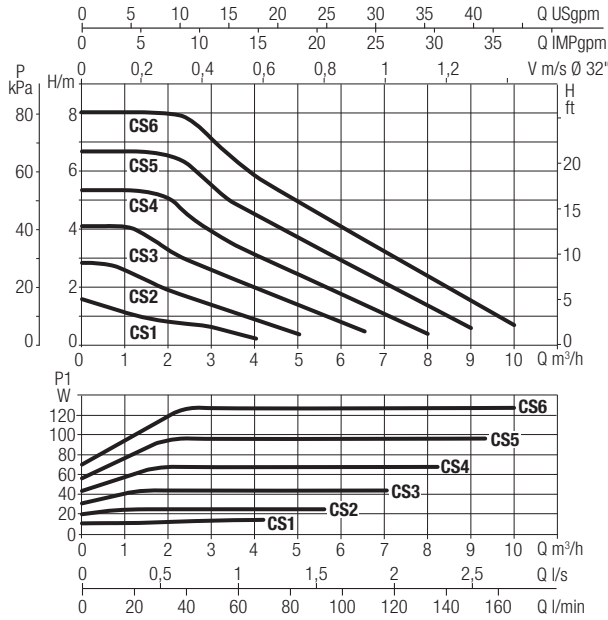

PPx = Proportional Differential Pressure - curve x
CPx = Constant Differential Pressure - curve x
CSx = Constant Speed - curve x

The curves are based on kinematic viscosity values = 1 mm²/s and density equal to 1000 kg/m³. Curve tolerance according to ISO 9906. Fixed speed curves available on the DNA.

MODEL	CENTRE DISTANCE mm	COUNTERFLANGES ON REQUEST	POWER INPUT 50/60 Hz	P1 MAX W	In A	EEI*	MINIMUM SUCTION PRESSURE			Q.TY x PALLET	WEIGHT Kg
							t°	90°	100°		
EVOPLUS LITE SAN 80/220-F32	220	DN 32 PN 6	220/240 V	127	1,04	EEI ≤ 0,21	m.c.w	20	25	64	7,2

* The parameter of reference for the more efficient circulators is EEI ≤ 0,20.

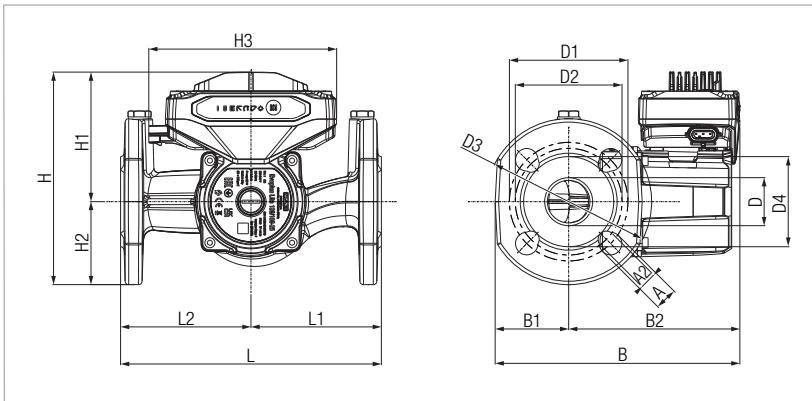

A1	A2	B	B1	B2	D
19	14	205	67	138	40

D1	D2	D3	D4	H	H1
100	90	140	76	179	109

H2	H3	L	L1	L2
70	159	220	110	110

EVOPLUS LITE SAN 80/250-F40 - WET ROTOR ELECTRONIC CIRCULATORS

Pumped liquid temperature range: from -20°C up to +110°C - Maximum operating pressure: 16 bar (1600 kPa)

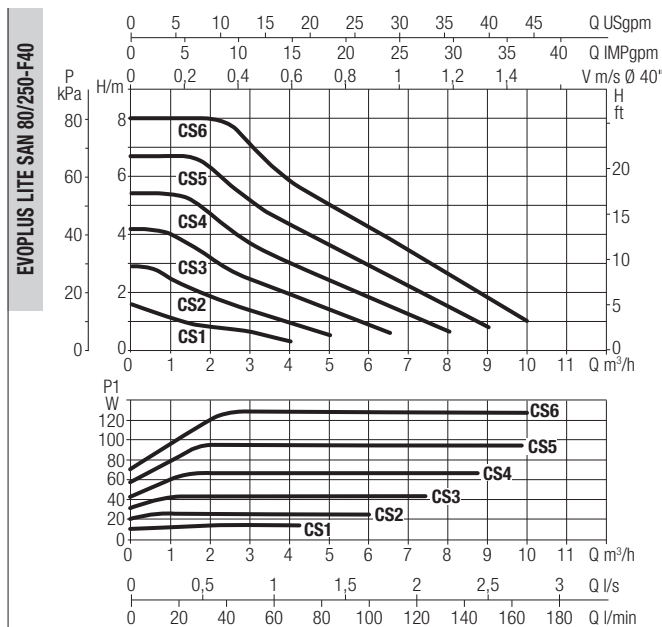
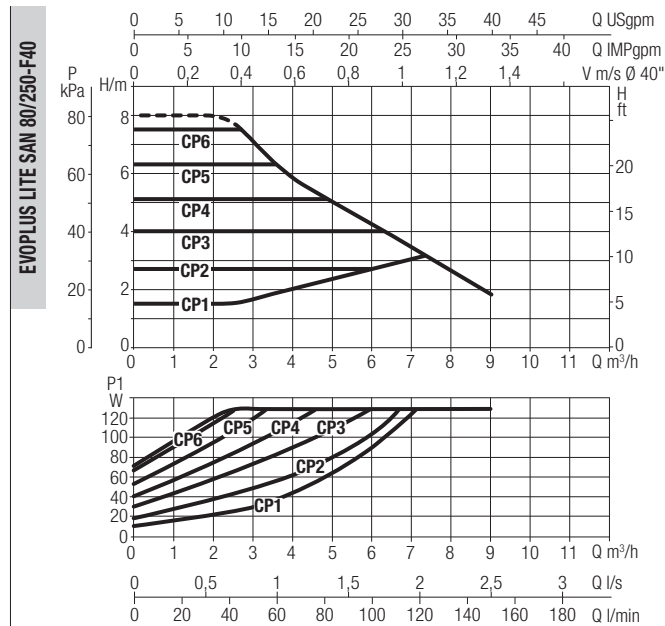
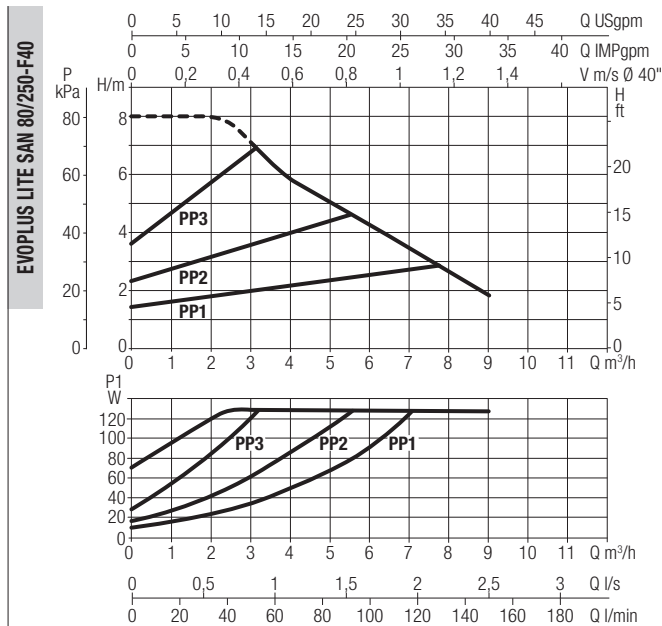

PPx = Proportional Differential Pressure - curve x
CPx = Constant Differential Pressure - curve x
CSx = Constant Speed - curve x

The curves are based on kinematic viscosity values = 1 mm²/s and density equal to 1000 kg/m³. Curve tolerance according to ISO 9906. Fixed speed curves available on the DNA.

MODEL	CENTRE DISTANCE mm	COUNTERFLANGES ON REQUEST	POWER INPUT 50/60 Hz	P1 MAX W	In A	EEI*	MINIMUM SUCTION PRESSURE			Q.TY X PALLET	WEIGHT Kg
							t°	90°	100°		
EVOPLUS LITE SAN 80/250-F40	250	DN 40 PN 10	220/240 V	128	1,04	EEI ≤ 0,20	m.c.w	20	25	64	7,7

* The parameter of reference for the more efficient circulators is EEI ≤ 0,20.

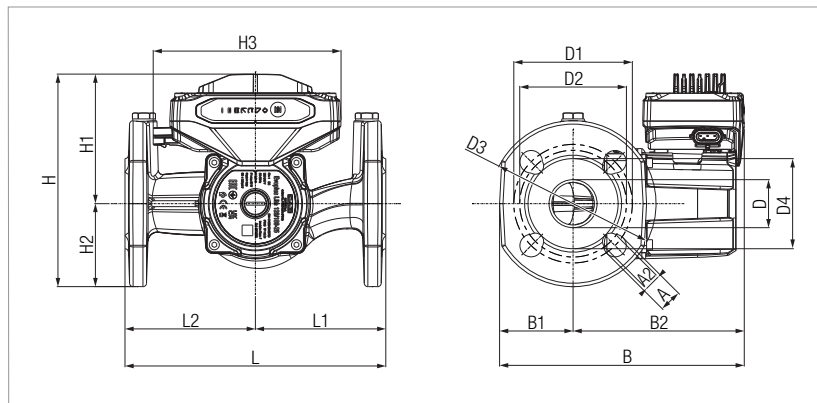

A1	A2	B	B1	B2	D
19	14	201	74	127	43

D1	D2	D3	D4	H	H1
110	100	150	84	184	109

H2	H3	L	L1	L2
75	159	250	125	125

EVOPLUS LITE SAN 120/180-25 - WET ROTOR ELECTRONIC CIRCULATORS

Pumped liquid temperature range: from -20°C up to +110°C - Maximum operating pressure: 16 bar (1600 kPa)

EVOPLUS LITE SAN 120/180-25

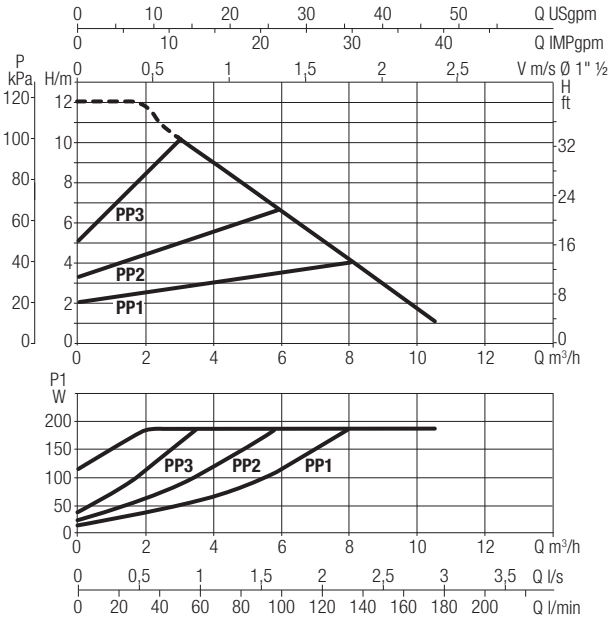

EVOPLUS LITE SAN 120/180-25

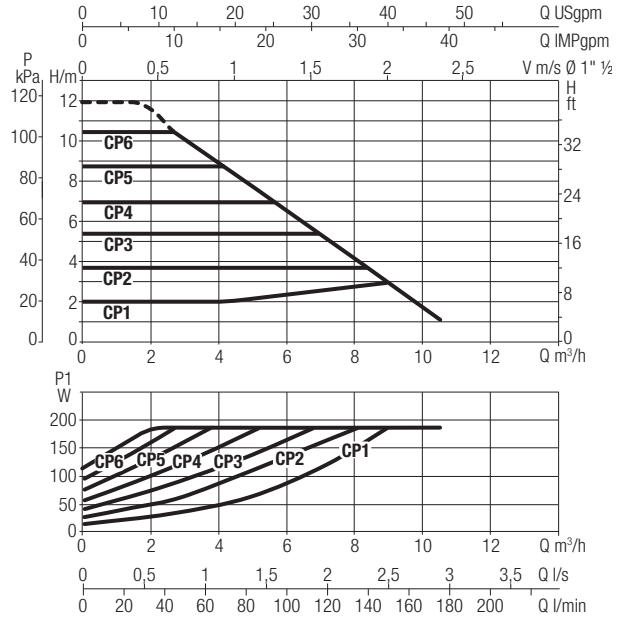

EVOPLUS LITE SAN 120/180-25

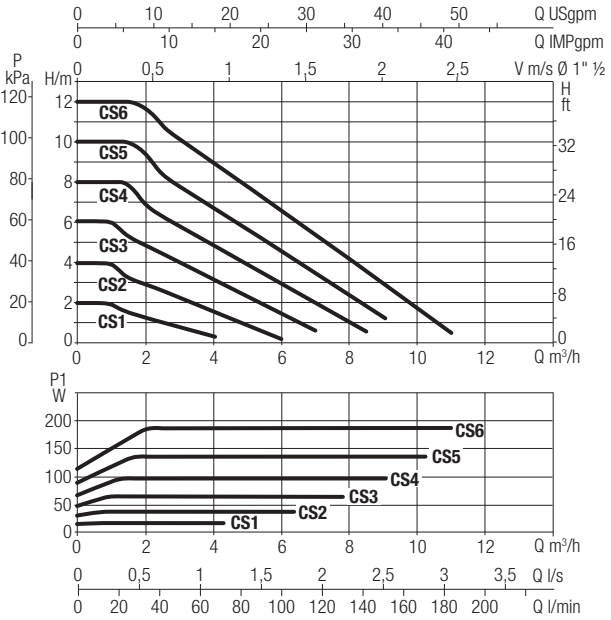

PPx = Proportional Differential Pressure - curve x
CPx = Constant Differential Pressure - curve x
CSx = Constant Speed - curve x

The curves are based on kinematic viscosity values = 1 mm²/s and density equal to 1000 kg/m³. Curve tolerance according to ISO 9906. Fixed speed curves available on the DNA.

MODEL	CENTRE DISTANCE mm	COUNTERFLANGES ON REQUEST	POWER INPUT 50/60 Hz	P1 MAX W	In A	EEI*	MINIMUM SUCTION PRESSURE			Q.TY x PALLET	WEIGHT Kg
							t°	90°	100°		
EVOPLUS LITE SAN 120/180-25	180	-	220/240 V	187	1,49	EEI ≤ 0,20	m.c.w	20	25	92	3,7

* The parameter of reference for the more efficient circulators is EEI ≤ 0,20.

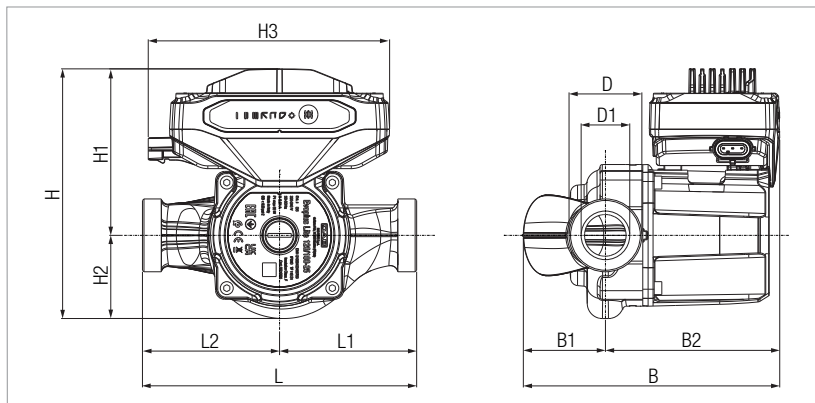

B	B1	B2	D	D1	H
168	54	114	1½"	32	164
H1	H2	H3	L	L1	L2
109	55	159	180	90	90

EVOPLUS LITE SAN 120/220-F32 - WET ROTOR ELECTRONIC CIRCULATORS

Pumped liquid temperature range: from -20°C up to +110°C - Maximum operating pressure: 16 bar (1600 kPa)

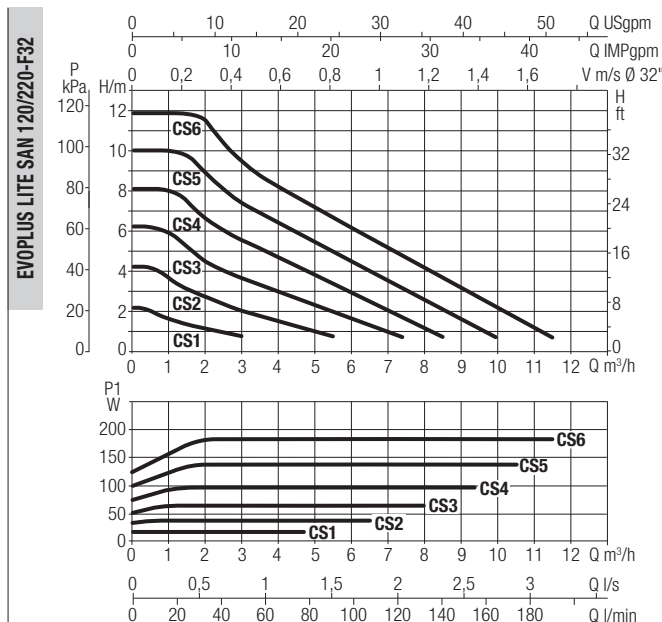
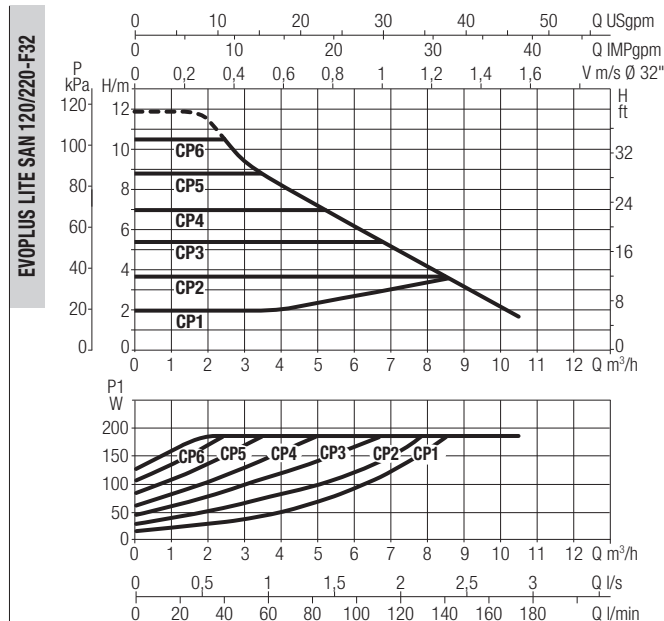
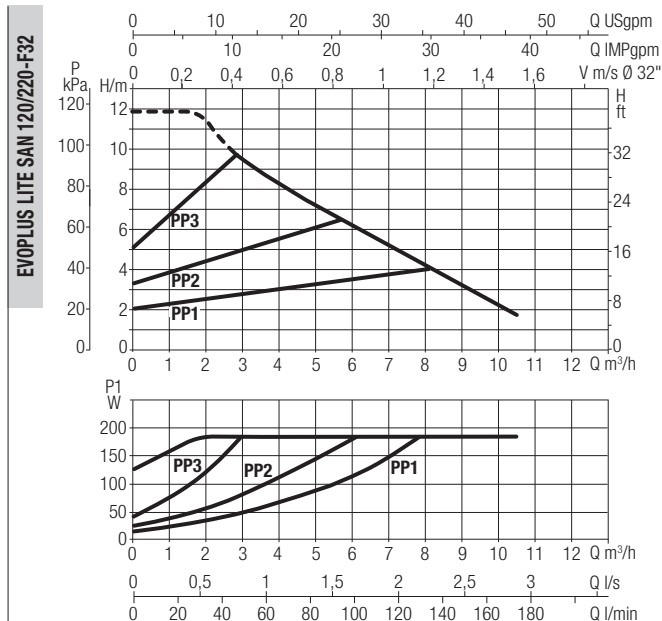

PPx = Proportional Differential Pressure - curve x

CPx = Constant Differential Pressure - curve x

CSx = Constant Speed - curve x

The curves are based on kinematic viscosity values = 1 mm²/s and density equal to 1000 kg/m³. Curve tolerance according to ISO 9906. Fixed speed curves available on the DNA.

MODEL	CENTRE DISTANCE mm	COUNTERFLANGES ON REQUEST	POWER INPUT 50/60 Hz	P1 MAX W	In A	EEI*	MINIMUM SUCTION PRESSURE			Q.TY X PALLET	WEIGHT Kg
							t°	90°	100°		
EVOPLUS LITE SAN 120/220-F32	220	DN 32 PN 6	220/240 V	185	1,49	EEI ≤ 0,21	m.c.w	20	25	64	7,2

* The parameter of reference for the more efficient circulators is EEI ≤ 0,20.

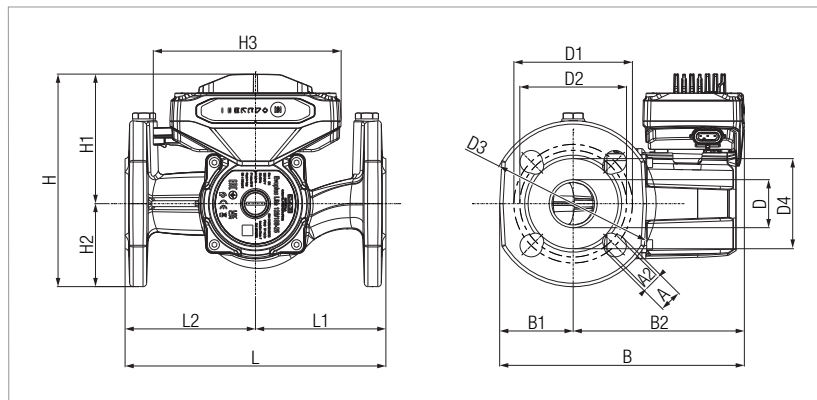

A1	A2	B	B1	B2	D
19	14	205	67	138	40

D1	D2	D3	D4	H	H1
100	90	140	76	179	109

H2	H3	L	L1	L2
70	159	220	110	110

EVOPLUS LITE SAN 120/250-F40 - WET ROTOR ELECTRONIC CIRCULATORS

Pumped liquid temperature range: from -20°C up to +110°C - Maximum operating pressure: 16 bar (1600 kPa)

EVOPLUS LITE SAN 120/250-F40

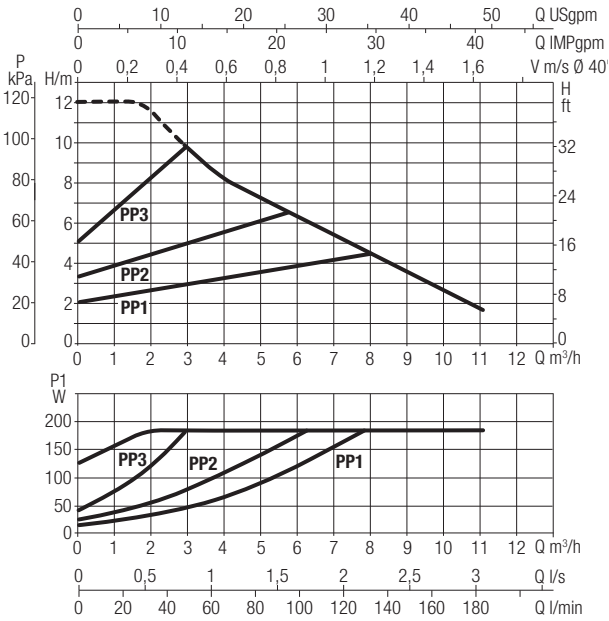

EVOPLUS LITE SAN 120/250-F40

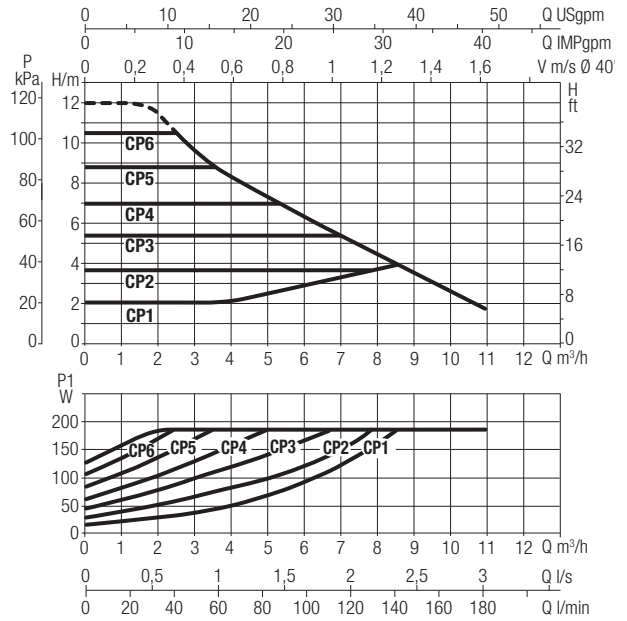

EVOPLUS LITE SAN 120/250-F40

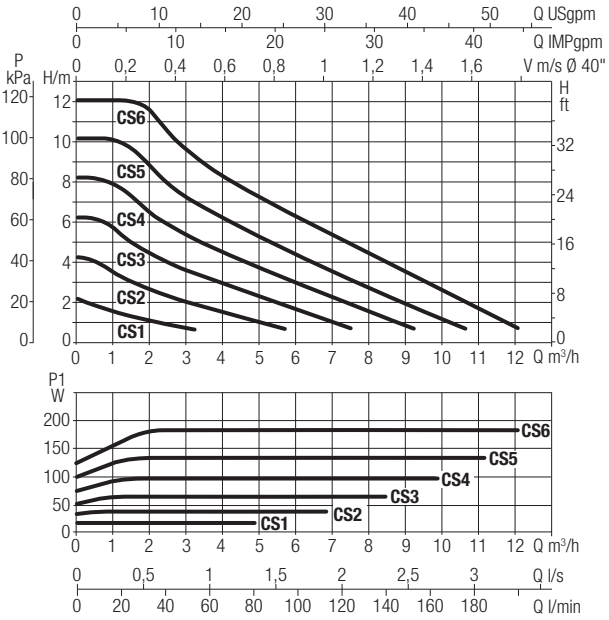

PPx = Proportional Differential Pressure - curve x
CPx = Constant Differential Pressure - curve x
CSx = Constant Speed - curve x

The curves are based on kinematic viscosity values = 1 mm²/s and density equal to 1000 kg/m³. Curve tolerance according to ISO 9906. Fixed speed curves available on the DNA.

MODEL	CENTRE DISTANCE mm	COUNTERFLANGES ON REQUEST	POWER INPUT 50/60 Hz	P1 MAX W	In A	EEI*	MINIMUM SUCTION PRESSURE			Q.TY x PALLET	WEIGHT Kg
							t°	90°	100°		
EVOPLUS LITE SAN 120/250-F40	250	DN 40 PN 10	220/240 V	186	1,49	EEI ≤ 0,21	m.c.w	20	25	64	7,7

* The parameter of reference for the more efficient circulators is EEI ≤ 0,20.

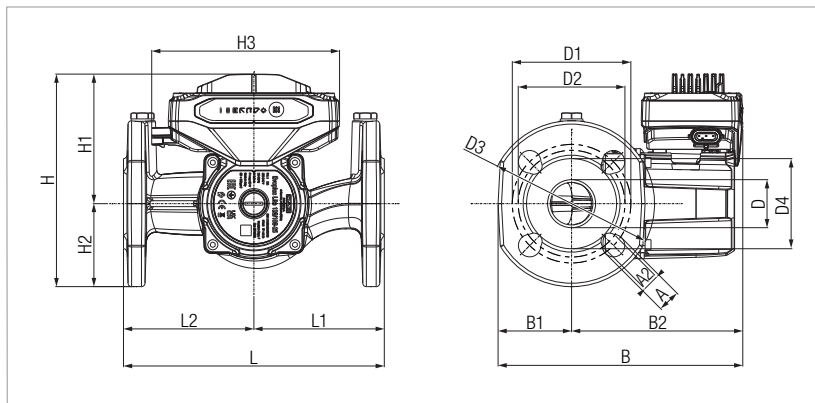

A1	A2	B	B1	B2	D
19	14	201	74	127	43

D1	D2	D3	D4	H	H1
110	100	150	84	184	109

H2	H3	L	L1	L2
75	159	250	125	125

DAB

PUMPS SELECTOR

On-line product selection



DAB PUMPS LTD.

Unit 6 Gilbert Court
Newcomen Way, Severalls Park
CO4 9WN
Colchester
ordersuk@dwtgroup.com
Tel. +44 0333 777 5010



DAB PUMPS IBERICA S.L.

Calle Verano 18-20-22
28850 - Torrejón de Ardoz - Madrid
Spain
Info.spain@dwtgroup.com
Tel. +34 91 6569545



DAB PUMPS (QINGDAO) CO. LTD.

No.10 Xindong Road
Jiulong Town,
Jiaozhou City
266319 Qingdao (Shandong) - China
sales.cn@dwtgroup.com
Tel. +86 400 186 8280
Fax +86 53286812210



DAB PUMPS BV

'tHofveld 6 C1
1702 Groot Bijgaarden - Belgium
info.belgium@dwtgroup.com
Tel. +32 2 4668353



DAB PUMPS HUNGARY KFT.

H-8800
Nagykanizsa, Buda Ernő u.5
Hungary
Tel. +36 93501700



DAB PUMPS DE MÉXICO, S.A. DE C.V.

Av Amsterdam 101 Local 4
Col. Hipódromo Condesa,
Del. Cuauhtémoc CP 06170
Ciudad de México
Tel. +52 55 6719 0493



DAB PUMPS B.V.

Statenlaan, 4
5223 LA, 's-Hertogenbosch
Nederland
info.nl@dabpumps.com
Tel. +31 416 387280



DAB PUMPS POLAND Sp. z o.o.

Ul. Janka Muzykanta 60
02188 Warszawa - Poland
sprzedaz@dabpumps.com.pl



DAB PUMPS OCEANIA PTY LTD

426 South Gippsland Highway,
Dandenong South VIC 3175 - Australia
info.oceania@dwtgroup.com
Tel. +61 1300 378 677



DAB PUMPS INC.

3226 Benchmark Drive
Ladson, SC 29456 - USA
info.usa@dwtgroup.com
Tel. 1- 843-797-5002
Fax 1-843-797-3366



DAB PUMPS GMBH

Am Nordpark 3
D - 41069 Mönchengladbach - Germany
info.germany@dwtgroup.com
Tel. +49 2161 47388-0
Fax +49 2161 47388-36



DAB PUMPS SOUTH AFRICA (PTY) LTD

Twenty One industrial Estate,
16 Purlin Street, Unit B, Warehouse 4
Olifantsfontein -1667 - South Africa
info.sa@dwtgroup.com
Tel. +27 12 361 3997



PT DAB PUMPS INDONESIA

Satrio Tower lantai 26
unit C-D, Jl. Prof. Dr. Satrio Kav. C4,
Kel. Kuningan Timur, Kec. Setiabudi, Kota Adm.
Jakarta Selatan, Prov. DKI Jakarta. - Indonesia
Tel. +62 2129222850